



# Company Profile

Omnicell is a leading provider of medication and medical supply management solutions that serves the entire continuum of care. Driven by a passion to improve patient care and outcomes – we deliver value to hospitals, health systems, post-acute care settings, and patients in the home, via state-of-the-art automated dispensing systems, enterprise inventory management, and medication adherence solutions.

Since 1992, Omnicell has been inspired to create safer and more efficient ways to manage medications and supplies across all care settings. Omnicell is revolutionizing the patient medication experience from hospital to home by empowering providers to keep each patient at the center of care.

In 2012, Omnicell introduced their medication adherence division by acquiring medication adherence packaging specialists, MTS Medication Technologies, located in St. Petersburg, Florida. In 2016, they added experts in patient engagement software, Ateb, in Raleigh, NC to the division. These facilities develop and manufacture over 1 million adherence blister cards a day along with a complete line of automated packaging equipment to support blister card fulfillment and software to manage patient engagement in pharmacies.

Omnicell's innovative medication adherence solutions, used by over 32,000 institutional and retail pharmacies in North America and the United Kingdom, are designed to improve patient engagement and adherence to prescriptions, helping to reduce costly hospital readmissions.

## Contact Information

**Customer Service 800.845.0053**

**Technical Service 800.671.0587**

**Sales Assistance 800.671.0589**

**Account #** \_\_\_\_\_

**Sales Representative** \_\_\_\_\_

**Customer Service Representative** \_\_\_\_\_



# Table of Contents

<b>Patient Engagement Solutions</b>	
Omnicell Patient Engagement	5
Omnicell MTM (Medication Therapy Management)	5
Omnicell Targeted Patient Interventions	5
Omnicell Medication Synchronization	6
Omnicell Immunization Solutions	7
Omnicell Patient Communications	8
<b>Getting Started with Multimed Adherence Packaging</b>	11
Handpacking with Cold Seal Non-Perforated Packaging	12
Handpacking with Heat Seal Non-Perforated Packaging	14
<b>The Next Step in Multimed Adherence Packaging</b>	16
Omnicell Guided Packing	17
Perforated Packaging	19
<b>Expanding Through Automation with Multimed Packaging</b>	21
Omnicell VBM 200F	22
<b>Getting Started with Single Dose Packaging</b>	27
Cold Seal Blisters	29
Handpacking Standard Cold Seal Cards	30
Handpacking One-Piece Cold Seal Cards	35
<b>The Next Step in Single Dose Packaging</b>	36
Automated Sealers	38
Heat Seal Blisters	39
Handpacking Standard Heat Seal Cards	40
Handpacking One-Piece Heat Seal Cards	45
Select Seal™ & Med Cards	48
Control Cards	53
Red Cards	54
Trap Door Cards	56
Mealtime Cards	57
14/15/16 Dose and Short-Cycle Cards	58
Miscellaneous Cards	60
<b>Opti-Pak</b>	62
<b>Unit Dose/Reclaimable</b>	64
<b>Printing Solutions</b>	68
Software	69
Unit Dose Foil Labeling System	70
License Plate Labeling System	71
PillVue Color Labeling System	72
Pre-pack Label Applicator	73
<b>Expand Through Automation with Single Dose Packaging</b>	74
Packaging Accessories	75
Semi-Automated Fillers & Sealers	76
Deblistering Machine	78
<b>Single Dose Automation</b>	79
AccuFlex	80
Express II	81
SureMed by Omnicell Packaging for DOSIS Automation	81
<b>Medication Cabinets</b>	84
<b>Labels &amp; Printing Supplies</b>	86
Custom Labels	87
Stock Labels	88
Specialty Labels	96
Software Specific Labels	98
Ribbons	115
Foil	116

With You on  
the Medication  
Adherence Journey



# SureMed by Omnicell

## Multimed Marketing Opportunities

Omnicell helps you promote your business by offering free tools to help market to retail customers, physicians, and long term care facilities

### Point of Sale Display Kit

**Introduce the Benefits of Adherence Packaging to Customers**

- Countertop display with “What is SureMed?” brochure
- Educational pamphlet on the importance of adhering to prescription medication regimens, tips for managing multiple medications and how to use SureMed cards
- SureMed Window decal communicating to customers that you offer SureMed packaging
- Web link with images, presentations, press releases and more!
- Available for perforated and non-perforated cards



**Ask Your Sales Representative to Send You a FREE Kit Today**

### SureMed by Omnicell Find-a-Pharmacy

#### Get Noticed and Grow Your Business

- Company information appears in find-a-pharmacy search
- Omnicell will be promoting on social media and PR efforts

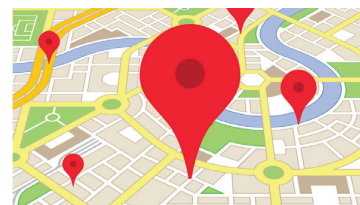

**Register Now on [omnicell.com/findapharmacy](http://omnicell.com/findapharmacy)**

## Omnicell Patient Engagement

**Omnicell Patient Engagement** is a single, web-based platform that hosts all functionality to guide and track patient interventions, appointments, and notes.

The Patient Engagement platform integrates with pharmacy management systems (PMS), facilitating bidirectional data flow. It also uses predictive analytics to prioritize patient interventions and pharmacy tasks.



## Omnicell MTM (Medication Therapy Management)

**Omnicell MTM** supports high-efficiency pharmacy interventions to improve patient outcomes, reduce healthcare costs, and maximize pharmacy services profitability.

### **Solution Benefits**

- Increases patient medication adherence rates
- Creates opportunity to expand revenue channels
- Integrates seamlessly with existing pharmacy workflow
- Improves overall MTM process efficiency



## Omnicell Targeted Patient Interventions

**Omnicell Targeted Patient Interventions** deliver proactive outreach methods at the right time to high-value, at-risk patients to drive improved adherence and outcomes.

### **Solution Benefits**

- Improve medication adherence
- Achieve better patient health outcomes
- Optimize patient retention
- Promote loyalty with enhanced customer service
- Increase script growth

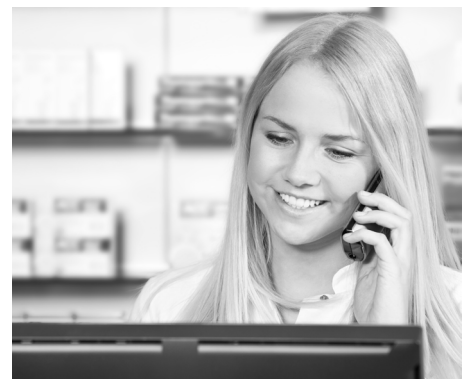

# Omnicell Medication Synchronization

Raise PDC scores, reduce DIR fees, and retain more patients with **Omnicell Medication Synchronization**

## Getting Started

- Coordinates a patient's chronic prescriptions to be picked up at the same time each month
- Provides opportunity for pharmacy to intervene with the patient on a regular schedule

## Next Steps

- Utilize big data and predictive analytics to find targeted patients to enroll into the program
- Integrate with your pharmacy management system (PMS) for bidirectional data flow between the PMS and the Omnicell Patient Engagement platform.
- Achieve near-perfect adherence/PDC (Proportion of Days Covered) scores



# Omnicell Immunization Solutions

Drive sales and enhance your vaccination workflow with  
**Omnicell Immunization Solutions**

## Getting Started

- Target eligible patients for immunization interventions such as flu, pneumonia, shingles and more

## Next Steps

- Query the state registry (where available)
- Automate reporting to the state registry
- Track and document vaccine administration





# Omnicell Patient Communications

Save time, enhance engagement, and grow script volumes with **Omnicell Patient Communications**

## Getting Started

**Maximize your profitability through patient communications**

- Omnicell IVR (Interactive Voice Response)
- Omnicell Inbound Patient Communications
- Omnicell Outbound Patient Communications
- Omnicell Hosted IVR



### **Omnicell IVR**

Increases patient access to the pharmacy 24 hours / 7 days a week through automation, so you can maximize your time and valuable resources for patient engagement.

### **Omnicell Inbound Patient Communications**

Presents additional prescriptions that are due or overdue to be filled when a patient successfully requests a refill, increasing patients' average days on therapy by 8%.\*



### **Omnicell Outbound Patient Communications**

Deliver real-time, relevant messaging through automated patient outreach methods to increase prescription sales, improve medication adherence, and reduce return to stock rates.

### **Omnicell Hosted IVR**

The enhanced hosted IVR gives customers an agile platform to improve the patient experience without the need for on-site hardware.

\*8% increase pertains only to medications for which Omnicell Inbound Patient Communications are used

# Growing with SureMed by Omnicell Multimed Packaging Solutions

## Expanding Through Automation

- Multimed Automated Solutions



## The Next Step

- Omnicell Guided Packing
- Perforated Packaging



## Getting Started

- Handpacking with Cold Seal Non-Perforated Packaging
- Handpacking with Heat Seal Non-Perforated Packaging



# SureMed by Omnicell Multimed Packaging

## Cold Seal and Heat Seal Accessories

### Cold-Seal Sealing Foam and Templates

**Item # 657-28**  
7- Day/ 28- Dose Sealing  
Foam for Multimed

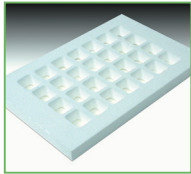

**Item #657-28-1**  
7- Day/ 28- Dose  
Sealing Foam for  
301-56 Multimed Cards

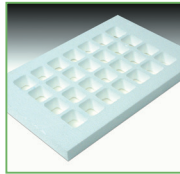

**Item #657-31**  
31- Day Sealing Foam  
for Multimed



**Item # 584-31**  
7-Day/ 28-Dose Sealing  
Cork for 300-96

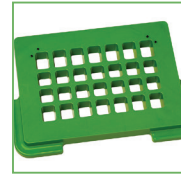

**Item #584-30**  
7- Day/ 28- Dose Sealing  
Template for 301-96



### Non-Perforated SureMed by Omnicell Multimed Paddles

**Item # 651-41**  
28 Dose Tri-Fold Paddle  
Do Not Use With Gemini  
7/8" thick

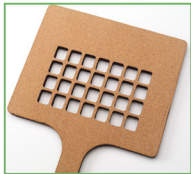

**Item # 651-41A**  
28 Dose Tri-Fold Paddle  
5/8" thick

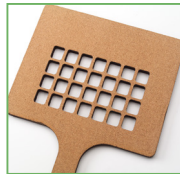

**Item # 651-42**  
31 Dose Tri-Fold Paddle  
5/8" thick

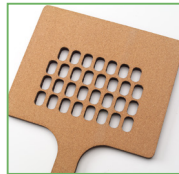

**Item # 651-38**  
31 Dose Bi-Fold 2-Up Paddle  
5/8" thick

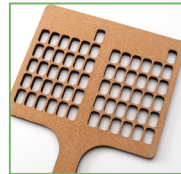

### Perforated SureMed Paddles

**Item # 651-41W**  
Perforated SureMed  
Small 28 (7x4) Paddle  
Do Not Use With Gemini  
7/8" thick

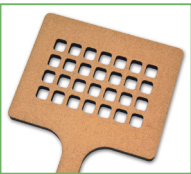

**Item # 651-39**  
Perforated SureMed  
Medium 28 (7x4) Paddle  
Do Not Use With Gemini  
7/8" thick



**Item # 651-01**  
Perforated SureMed  
Medium 30 (6x5) Paddle  
Do Not Use With Gemini  
7/8" thick



**Item # 651-30**  
Perforated SureMed  
Large 28 (7x4) Paddle  
Do Not Use With Gemini  
1 1/8" thick

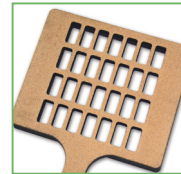

### Miscellaneous Accessories

**Item # 660-00**  
Cold Seal Roller





# Getting Started

## Expanding Through Automation

- Multimed Automated Solutions



## The Next Step

- Guided Packing Software
- Perforated Packaging



## Getting Started

- Handpacking with Cold Seal Non-Perforated Packaging
- Handpacking with Heat Seal Non-Perforated Packaging



# Getting Started with Multimed Packaging

## Handpacking SureMed by Omnicell Cold Seal Cards

### Non-Perforated Packaging:

These non-perforated cards serve as a visual reminder of which medications have been taken, making them an excellent tool to help ensure adherence.

### 7x4 Tri-Fold, Cold Seal with Standard Blister

### #301-25 PACK

#### Pack Includes

- 250 Cards
- 250 Blisters
- 1 Foam Template

#### Recommended Accessories:

- Roller #660-00

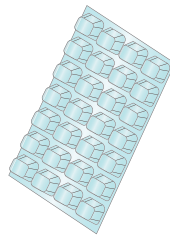
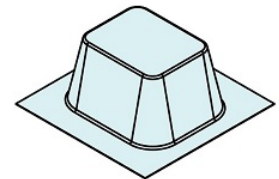
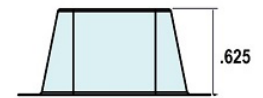
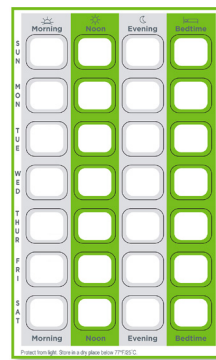

Blisters

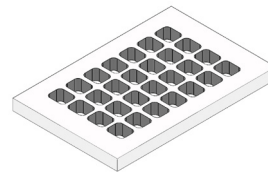

Foam Template

### 7x4 Tri-Fold, Cold Seal with Standard Blister

### Item #301-25DC PACK

#### Co-Branded Option

#### Pack Includes:

- 250 Cards
- 250 Blisters
- 1 Foam Template

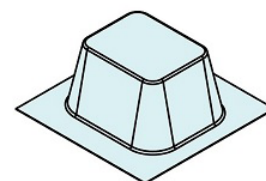

Blisters

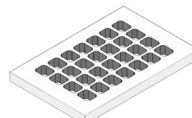

Foam Template

# Getting Started with Multimed Packaging

## Handpacking SureMed by Omnicell Cold Seal Cards

### 7x4 Tri-Fold, Cold Seal with Deeper Blister

Item #301-56 PACK

**Pack Includes:**

- 250 Cards
- 250 Blisters
- 1 Foam Template

**Recommended Accessories:**

- Roller #660-00

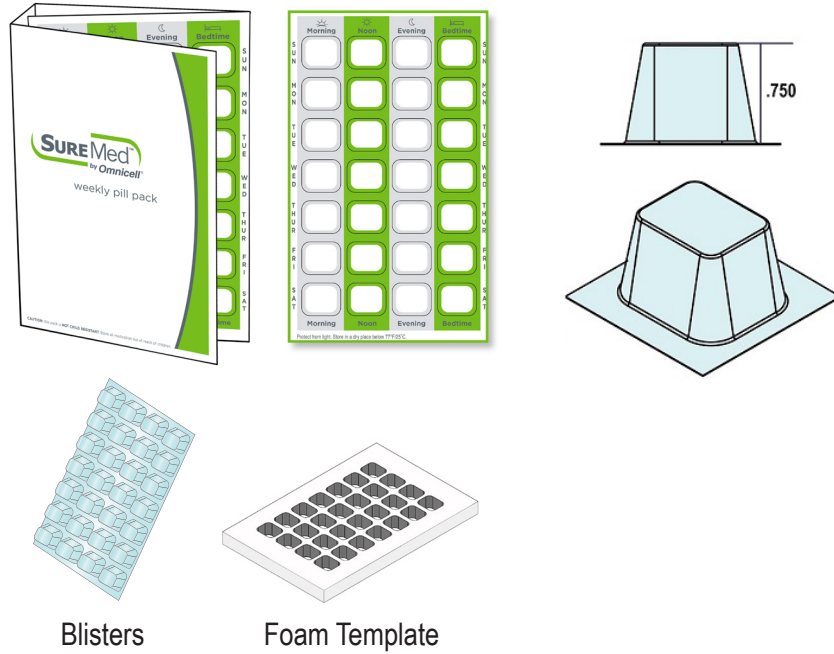

Blisters

Foam Template

### 7x4 Tri-Fold, Cold Seal with Deeper Blister

Item #301-56DC PACK

**Co-Branded Option**

**Pack Includes:**

- 250 Cards
- 250 Blisters
- 1 Foam Template

**Recommended Accessories:**

- Roller #660-00

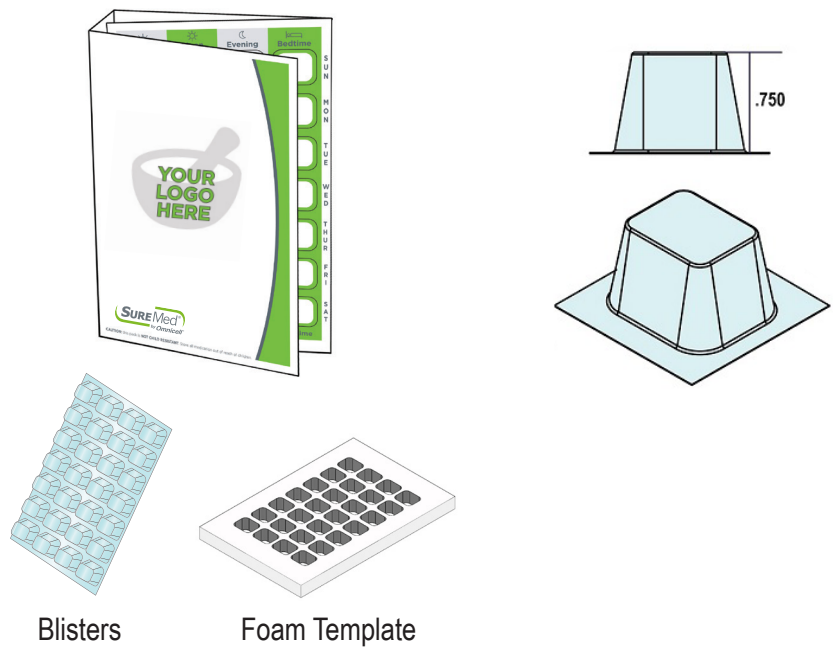

Blisters

Foam Template

# Getting Started with Multimed Packaging

## Handpacking SureMed by Omnicell Cold & Heat Seal Cards

### 31-Day Tri-Fold, Cold Seal, 250/Box

Item #301-17

#### Coordinating Blisters, 250/Box

Item No.	Description
204-10	31-Day

#### Recommended Accessories:

- Foam Template #657-31
- Roller #660-00

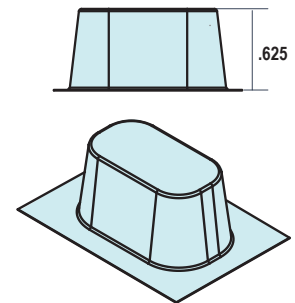
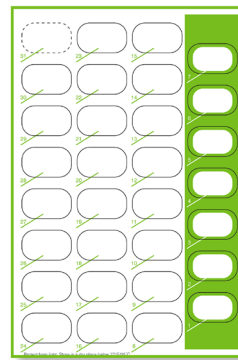

### 31-Day Tri-Fold, Heat Seal, 250/Box

Item #301-10

#### Coordinating Blisters, 250/Pack

Item No.	Description
204-10	31-Day

#### Recommended Accessories:

- Paddle #651-42

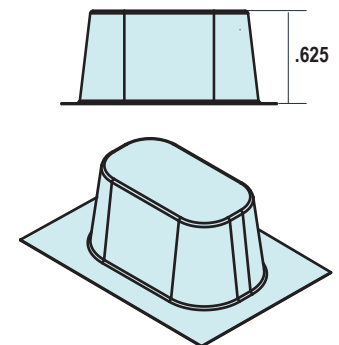
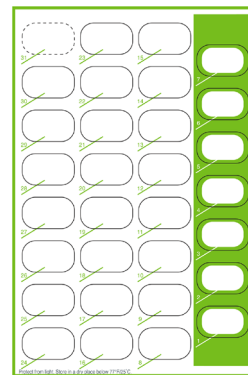

### 31-Day Tri-Fold, Heat Seal Calendar, 250/Box

Item #301-11

#### Coordinating Blisters, 250/Box

Item No.	Description
204-10	31-Day

#### Recommended Accessories:

- Paddle #651-42

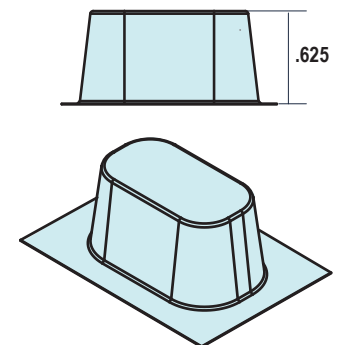
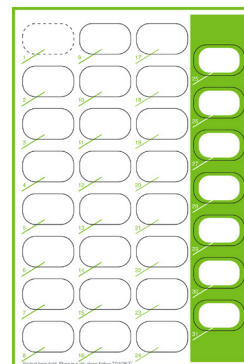

# Getting Started with Multimed Packaging

## Handpacking SureMed by Omnicell Heat Seal Cards

### 7x4 Tri-Fold, Heat Seal, 250/Box

Item #301-21

#### Coordinating Blisters, 250/Box

Item No.	Description
200-46	Blister
203-46	Blister Amber
200-56	Deeper Blister*

\*DO NOT USE in Gemini.

#### Recommended Accessories:

- Paddle for Standard Blister #651-41A
- Paddle for Deeper Blister #651-41

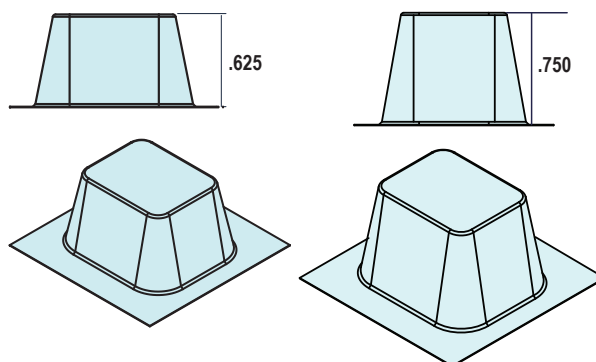

### 31-Day Bi-Fold, Heat Seal, 500/Box

Item #300-17

#### Coordinating Blisters, 1,000/Box

Item No.	Description
200-19	31-Day

#### Recommended Accessories:

- Paddle #651-38

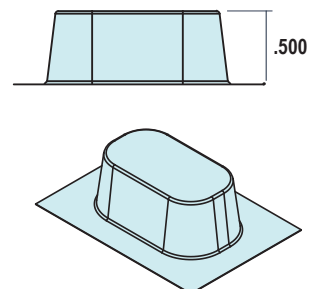
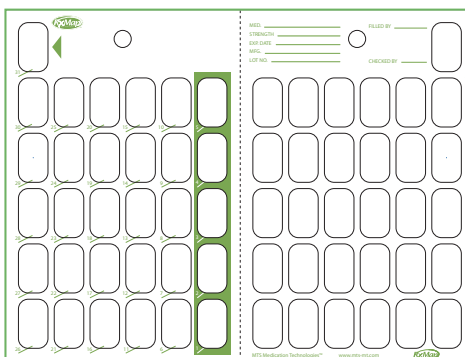

# The Next Step

## Expanding Through Automation

- Multimed Automated Solutions



## The Next Step

- Omnicell Guided Packing
- Perforated Packaging



## Getting Started

- Handpacking with Cold Seal Non-Perforated Packaging
- Handpacking with Heat Seal Non-Perforated Packaging





# The Next Step in Multimed Packaging

## SureMed by Omnicell Guided Packing

### SureMed by Omnicell Guided Packing Item #MTS-SWS-001

This cloud-based software can be accessed from any workstation within the pharmacy, providing greater options and flexibility to meet customer demand. This application works in conjunction with SureMed by Omnicell multimed adherence blister cards.

#### Recommended Accessories:

- HP PageWidePro 750DW Printer #B09-00-00-403
- Epson WF-8090 Printer #A-0590A
- SureMed by Omnicell 7x4 Bi-Fold, Cold Seal, Perforated Cards #300-96 or #301-96
- Coordinating blisters #206-37 or #206-39
- Template #584-31 or #584-30
- Roller #660-00



Home / Packing / Guided Fill

Home Pack Check Manage

Scan a drug Progress 4 Fulfillment

MxxxxxE GxxxxxxR GALLM-MMMP (DOB 03/01/1967)  
Thursday  
123 Sample Street Anywhere, FL 55555

Required for next pack Prepared when No longer required Tap Drug

FWCheck	Mark as Packed	Mark as Checked	On Hold	Exit	Reset
7	7	7	7		

Sequence	Pack	Dates	Label Barcode	Status
1	1 of 0	02/10/2016 - 02/17/2016	1-P45QF3	Packing Void
2	1 of 0	02/18/2016 - 02/24/2016	1-FELSCU	Packing Void
3	1 of 0	02/25/2016 - 03/02/2016	1-FJ0BLC	Packing Void
4	1 of 0	03/03/2016 - 03/09/2016	1-FKLLKS	Packing Void

Drug	Directions	Pack Qty	Total Qty	Drug Status
amlorazine 15 mg tablet 050791105	TAKE ONE TABLET BY MOUTH EVERY DAY	7	28	Packing Void
clobazepam 5.5 mg tablet 050503210	TAKE ONE TABLET BY MOUTH 2 TIMES A DAY	14	56	Not Packed
DailyVite tablet 050554710	Take 1 capsule by mouth daily	7	28	Not Packed
gabapentine 60 mg capsule delayed 473251019	TAKE ONE CAPSULE BY MOUTH EVERY DAY	7	28	Not Packed
lamotrigine 25				

	Morning	Noon	Evening	Bedtime
Thu	1			
Fri	1			
Sat	1			

MxxxxxE GxxxxxxR GALLM-MMMP  
Pack 1 of 0 (02/10/2016 - 02/17/2016) - 1-P45QF3

# The Next Step in Multimed Packaging

## SureMed by Omnicell Cold Seal Cards for Guided Packing

### 7x4 Bi-Fold, Cold Seal, Perforated 250/Box Item #300-96

Designed to print in one of the printers recommended below in conjunction with guided packing software

#### Coordinating Blisters, 250/Box

Item No.	Description
206-37	SureMed Standard Blister

#### Recommended Accessories:

- HP PageWidePro 750DW Printer #B09-00-00-403
- Epson WF-8090 Printer #A-0590A
- SureMed by Omnicell Guided Packing Software #MTS-SWS-001
- Template #584-31
- Roller #660-00

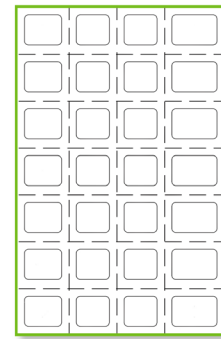

### 7x4 Bi-Fold, Cold Seal, Perforated 250/Box Item #300-96CB

#### Co-Branded Option

#### Coordinating Blisters, 250/Box

Item No.	Description
206-37	SureMed Standard Blister

#### Recommended Accessories:

- HP PageWidePro 750DW Printer #B09-00-00-403
- Epson WF-8090 Printer #A-0590A
- SureMed by Omnicell Guided Packing Software #MTS-SWS-001
- Template #584-31
- Roller #660-00

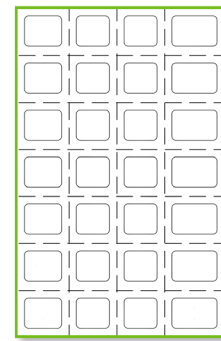
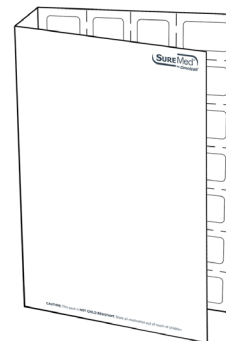



# The Next Step in Multimed Packaging

## SureMed by Omnicell Cold Seal Perforated Cards

### Perforated Packaging:

Each time-of-day blister can be detached from the larger card for ambulatory patients who are on the go.

## 7x4 Large Bi-Fold, Cold Seal, Perforated 250/Box Item #301-96

### Coordinating Blisters, 250/Box

Item No.	Description
206-39	SureMed Plus Blister

#### Recommended Accessories:

- HP PageWidePro 750DW Printer #B09-00-00-403
- Epson WF-8090 Printer #A-0590A
- SureMed by Omnicell Guided Packing Software #MTS-SWS-001
- Template #584-30
- Roller #660-00

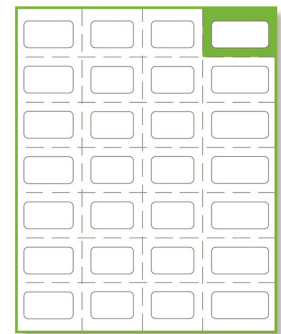

## 7x4 Large Tri-Fold, Cold Seal, Perforated, 250/Box Item #301-96CB

### Co-Branded Option

### Coordinating Blisters, 250/Box

Item No.	Description
206-39	SureMed Plus Blister

#### Recommended Accessories:

- HP PageWidePro 750DW Printer #B09-00-00-403
- Epson WF-8090 Printer #A-0590A
- SureMed by Omnicell Guided Packing Software #MTS-SWS-001
- Template #584-30
- Roller #660-00

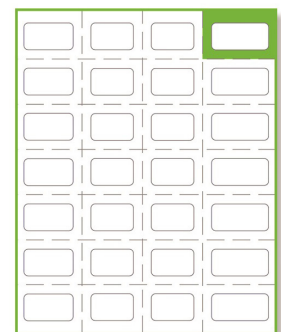
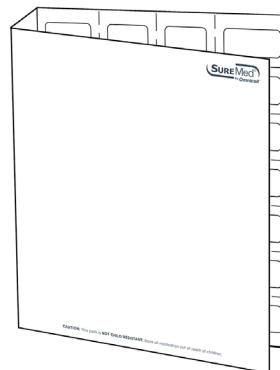

# The Next Step in Multimed Packaging

## SureMed by Omnicell Heat Seal Perforated Cards

### 30-Day Tri-Fold, Heat Seal, Perforated, 500/Box Item #301-30

#### Coordinating Blisters Monthly Card, 250/Case

Item No.	Description
205-30	30 Dose <b>Medium</b>

#### Recommended Accessories:

- Foil #680-30
- Paddle #651-01

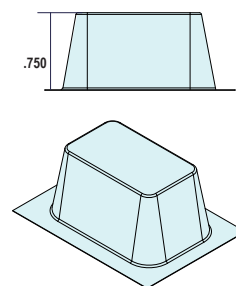
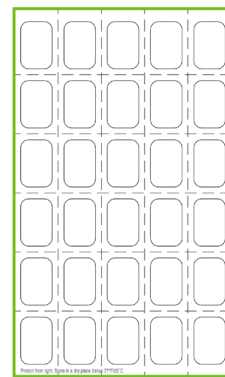

### 7x2 Large Tri-Fold - Heat Seal, Perforated, 500/Box Item #301-12

#### Coordinating Blisters

Item No.	Description
205-15XL	7-Day <b>Extra Large</b> (large capacity, 250/Box)

#### Recommended Accessories:

- Paddle # 651-30

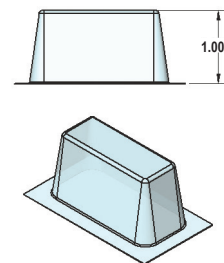
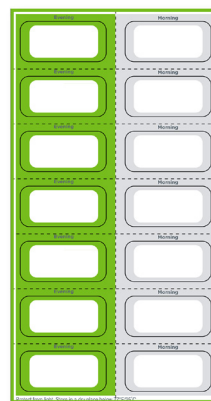

205-15XL

# Expanding Through Automation

## Expanding Through Automation

- Multimed Automated Solutions



## The Next Step

- Guided Packing Software
- Perforated Packaging



## Getting Started

- Handpacking with Cold Seal Non-Perforated Packaging
- Handpacking with Heat Seal Non-Perforated Packaging



# Omnicell VBM 200F

## Automation for SureMed® Multimed Adherence Cards

The Omnicell® VBM 200F is the only automated pharmacy solution that efficiently and accurately fills and checks SureMed® multiple medication blister cards. The VBM 200F ensures pharmacies have the competitive advantage to easily scale their business to improve adherence and patient outcomes today.

### Increase Revenue. Decrease Expenses.

Free up pharmacy staff and reduce operating expenses.

- Throughput of 35-40 sealed and audited cards per hour
- Small-footprint, ergonomic design that fits through a standard doorway
- Ease of access for cleaning and maintenance
- Does not require compressed air and can run on 110V
- Extremely intuitive and easy-to-use interface

### Accuracy You Can Trust

- The VBM 200F utilizes unparalleled and proven vision technology to verify every medication for each individual blister before the card is filled.
- Reduce Human Errors with Guided Light Manual Fill Trays
- Uninterrupted Workflow with ability to exchange/refill cassettes during production
- Process Tracking with Smart RFID Medication Trays
- Barcode Tracking Audit at the Workstation



# Omniceil VBM 200F

## Cold Seal Cards for Automation

7x4 Large Bi-Fold, Cold Seal, Perforated 250/Box      Item #301-96

**Coordinating Blisters, 250/Box**

*Item No.*      *Description*  
 206-39      SureMed Plus Blister

**Recommended Accessories:**

- VBM200F

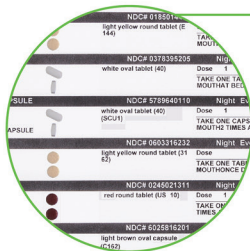

Consolidated label with **full-color drug images** and dosage instructions

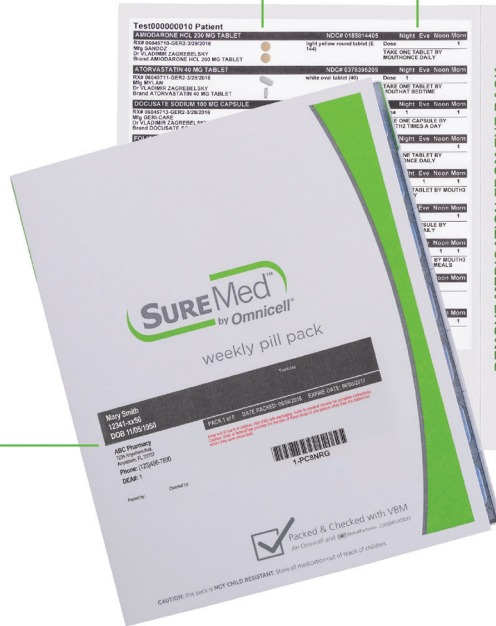

**Patient and Pharmacy Information** printed on the front of the card

**Drug information** on blister lidding



**Easy-to-understand, clearly marked day-of-the-week and time passes**

# Expanding Through Automation for Multimed Packaging

## Heat Seal Cards for Automation

### 7x4 Tri-Fold, Heat Seal, Perforated, 250/Box Item #300-90

#### Coordinating Blisters

Item No.	Description
206-37	Medium Blister

#### Recommended Accessories:

- OnDemand 400
- Foil # 680-38

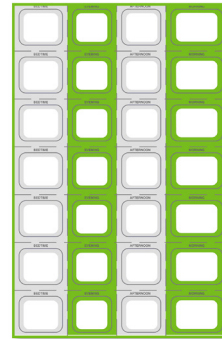

---

### 7x4 Large Tri-Fold, Heat Seal, Perforated, 250/Box Item #301-90

#### Coordinating Blisters

Item No.	Description
206-39	XL Blister

#### Recommended Accessories:

- OnDemand 400
- Foil # 680-39

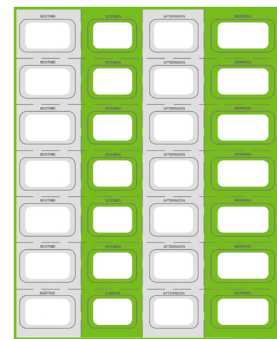



# Expanding Through Automation for Multimed Packaging

## Heat Seal Cards for Automation

### 7x4 Medium Tri-Fold, Heat Seal, Perforated, 500/BX

Item #301-33

#### Coordinating Blisters

Item No.	Description
205-27	28 Dose Medium

#### Recommended Accessories:

- OnDemand 400
- Foil #680-28

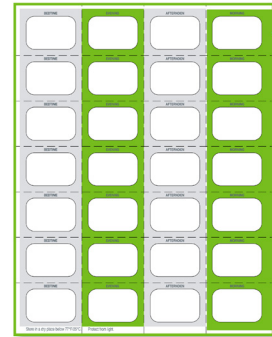

### 7x4 Large Tri-Fold, Heat Seal, Perforated, 500BX

Item #301-35

#### Coordinating Blisters

Item No.	Description
204-20XL	28 Dose Extra Large (large capacity, 250/BX)
204-20S	28 Dose Large (small capacity, 500/BX)

#### Recommended Accessories:

- OnDemand 400
- Foil #680-20

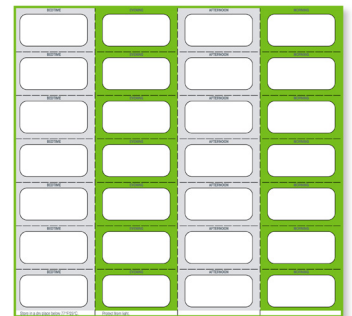

# Expanding Through Automation for Multimed Packaging

## Heat Seal Cards for Automation

### 28-Day Large Tri-Fold, Heat Seal Perforated, 500/Box

Item #301-36

#### Coordinating Blisters

Item No.	Description
204-20XL	28 Dose Extra Large (large capacity, 250/BX)
204-20S	28 Dose Large (small capacity, 500/BX)

#### Recommended Accessories:

- OnDemand 400
- Foil #680-20

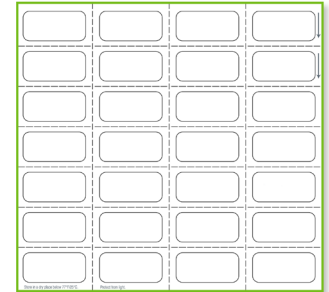

### 7x4 Medium Tri-Fold, 3 Color, Heat Seal, Perforated, 500/Box

Item #301-37

#### Coordinating Blisters

Item No.	Description
205-27	28 Dose Medium

#### Recommended Accessories:

- OnDemand 400
- Foil #680-28

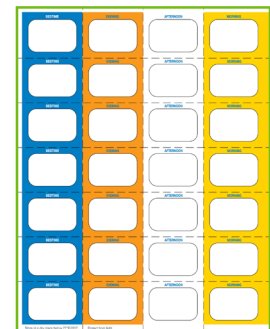



# Growing with SureMed by Omnicell Single Dose Packaging Solutions

## Expanding Through Automation

- Semi-Automated Fillers and Sealers
- Fully-Automated Single Dose Automation



## The Next Step

- Handpacking with Heat Seal Single Dose Packaging



## Getting Started

- Handpacking with Cold Seal Single Dose Packaging



# Growing with SureMed by Omnicell Single Dose Packaging Solutions

## Expanding Through Automation

- Semi-Automated Fillers and Sealers
- Full-Automated Single Dose Automation

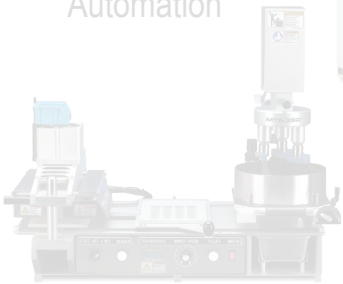

## The Next Step

- Handpacking with Heat Seal Single Dose Packaging



## Getting Started

- Handpacking with Cold Seal Single Dose Packaging



# Getting Started with Single Dose Packaging

## SureMed by Omnicell Cold Seal Blisters and Accessories

### Small

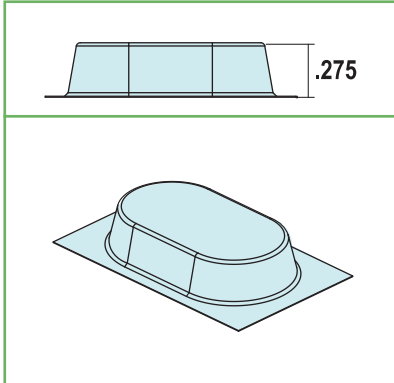

### Medium

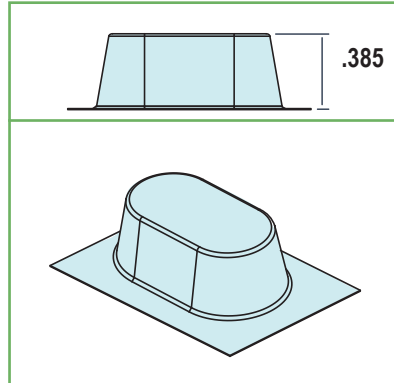

### Large

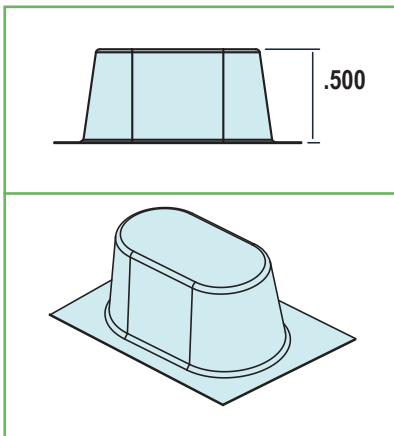

### Extra Large

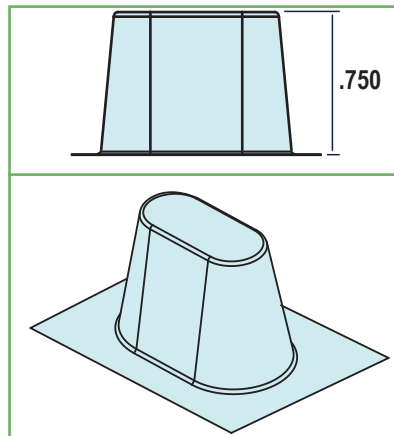

### Corks *Warning: Not to be used in heat sealers*

Item # 655-30  
30/31/32 Dose Cork



Item # 655-30A  
30/31/32 Dose Cork  
Deeper Blister



Item # 655-60  
60/62 Dose Cork



Item # 655-90  
90 Dose Cork

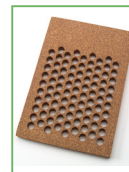

### Miscellaneous Accessories

Item # 660-00  
Cold Seal Roller





# Getting Started with Single Dose Packaging

## Handpacking with SureMed by Omnicell Cold Seal Cards

### 31-Day, 250/Box Item #300-58

#### Coordinating Blisters – Standard, 1,000/Box

Item No.	Description	
200-31	Small	
200-32	Medium	(250 Pack Available)
200-34	Large	(250 Pack Available)
200-52*	Extra Large	
203-30	Small Amber	
203-31	Medium Amber	
203-33	Large Amber	

\*Blister requires special triple layer cork to seal.

#### Recommended Accessories:

- Standard Cork #655-30
- Triple Layer Cork for XL #655-30A
- Roller #660-00

**Refer to Page 29 for Blister Sizes**

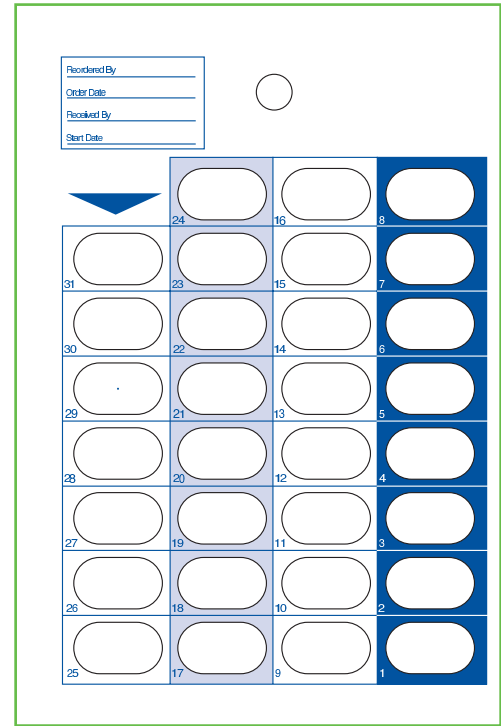

### 31-Day, 250/Box Item #300-58DC

#### Co-Branded Option

**Refer to Page 29 for Blister Sizes**

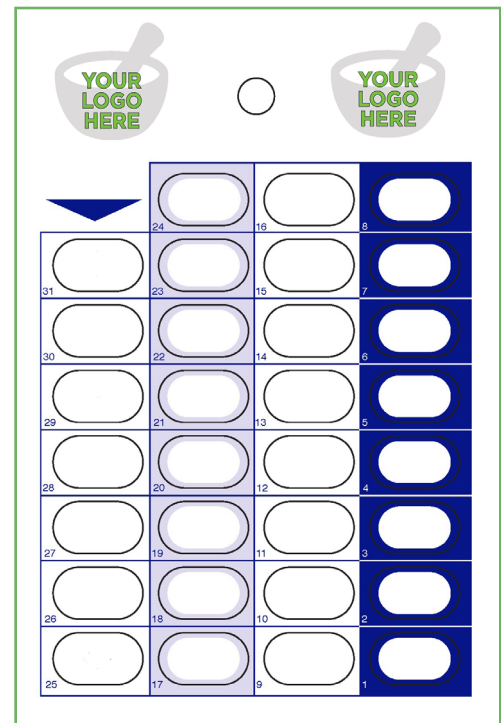

# Getting Started with Single Dose Packaging

## Handpacking with SureMed by Omnicell Cold Seal Cards

### 31-Day Calendar, 250/Box Item #300-59

#### Coordinating Blisters – Standard, 1,000/Box

Item No.	Description
200-31	Small
200-32	Medium (250 Pack Available)
200-34	Large (250 Pack Available)
200-52*	Extra Large
203-30	Small Amber
203-31	Medium Amber
203-33	Large Amber

\*Blister requires special triple layer cork to seal.

#### Recommended Accessories:

- Standard Cork #655-30
- Triple Layer Cork for XL #655-30A
- Roller #660-00

Refer to Page 29 for Sizes

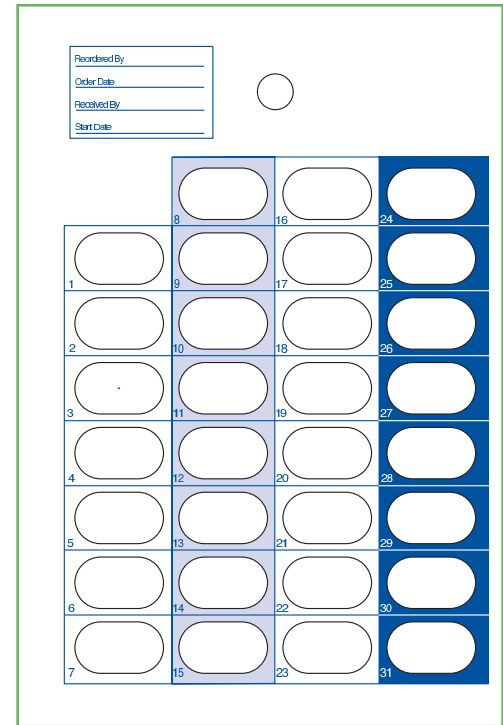

### 31-Day, 250/Box Item #300-59DC

#### Coordinating Blisters – Standard, 1,000/Box

Refer to Page 29 for Sizes

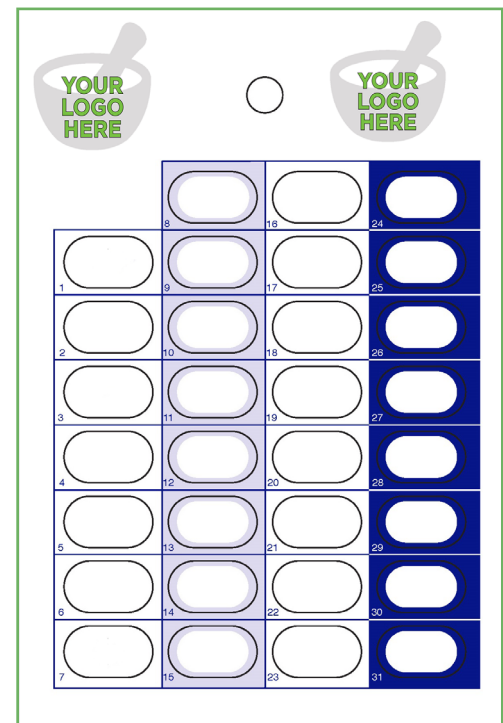

# Getting Started with Single Dose Packaging

## Handpacking with SureMed by Omnicell Cold Seal Cards

### 14-Day Card, 250/Box Item #314-61

#### Coordinating Blisters – Unit Dose, 1,000/Box

Item No.	Description
201-05	Large 14-Day

#### Recommended Accessories:

- Coordinating Cork #655-30
- Roller #660-00

Refer to Page 29 for Sizes

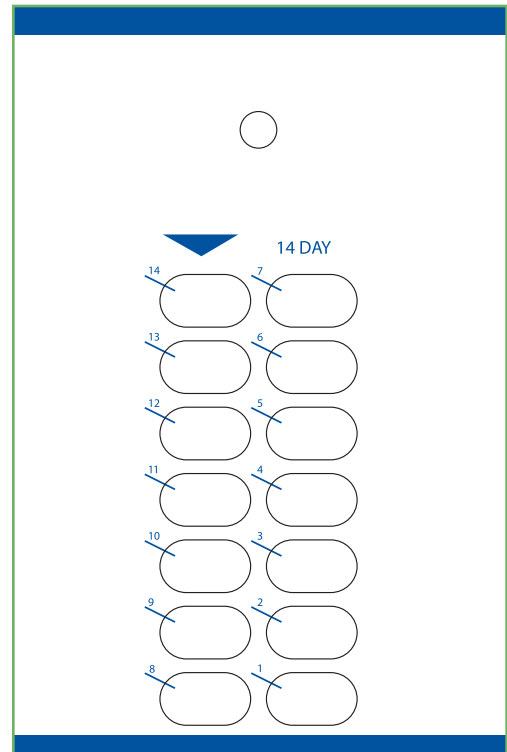

### 62-Day, 250/Box Item #300-64

#### Coordinating Blisters – Standard, 1,000/Box

(250 Pack Available)

Item No.	Description
200-23	62-Day
203-25	62-Day, Amber

#### Recommended Accessories:

- Coordinating Cork #655-60
- Roller #660-00

Refer to Page 29 for Sizes

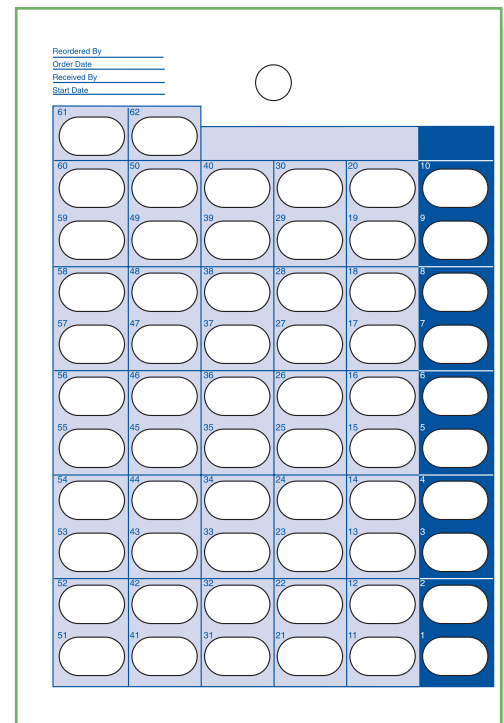
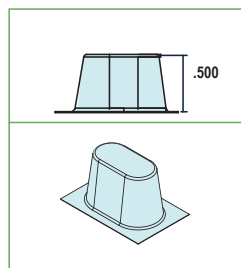



# Getting Started with Single Dose Packaging

## Handpacking with SureMed by Omnicell Cold Seal Cards

62-Day, 250/Box    Item #300-64DC

Co-Branded Option

Refer to Page 29 for Sizes

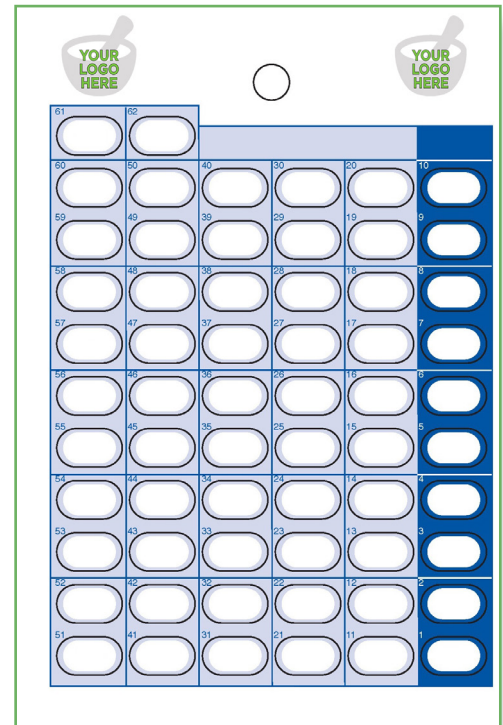

90-Day, 250/Box    Item #300-65

Coordinating Blisters – Standard, 1,000/Box

(250 Pack Available)

Item No.	Description
200-24	90-Day
203-26	90-Day, Amber

Coordinating Cork:  
#655-90

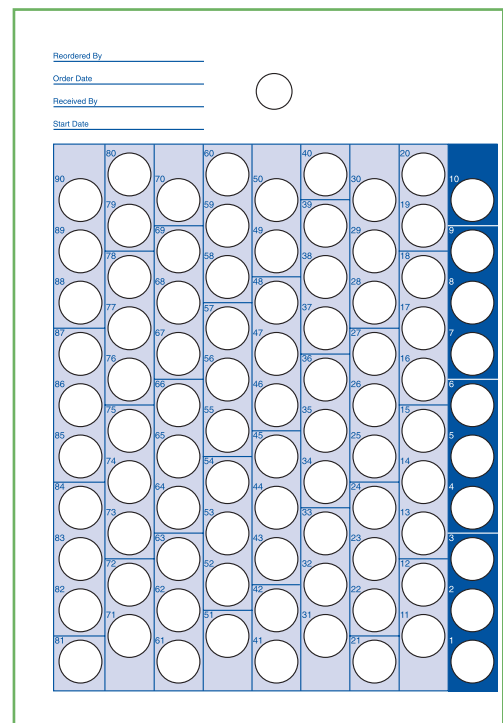
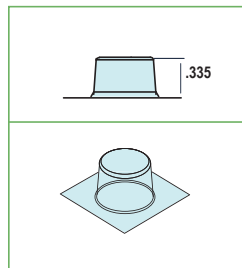



# Getting Started with Single Dose Packaging

## Handpacking with SureMed by Omnicell One-Piece Cold Seal Cards

**One-Piece Cold Seal Cards:** This card comes ready-to-go. Simply place meds in the blisters, peel the protective paper off the card flap and fold it over to seal the card.

### 31-Day Cold Seal, 250/Box

*Item No.*                      *Description*  
300-40-B31OV              31 Dose Card w/ Large Blister

*Recommended Accessories:*

- Coordinating Cork #655-30
- Roller #660-00

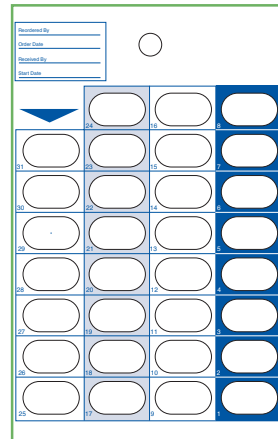

### 62-Day Cold Seal, 250/Box

*Item No.*                      *Description*  
300-41-B62                      62 Dose Card

*Recommended Accessories:*

- Coordinating Cork #655-60
- Roller #660-00

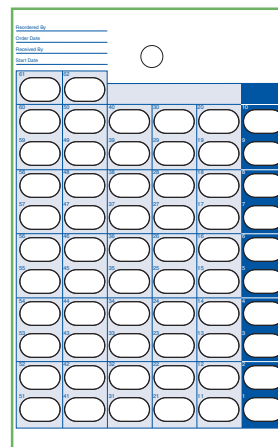

### 90-Day Cold Seal, 250/Box

*Item No.*                      *Description*  
300-42-B90                      90 Dose Card

*Recommended Accessories:*

- Coordinating Cork #655-90
- Roller #660-00

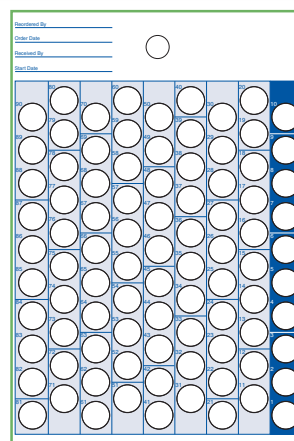

# Growing with SureMed by Omnicell Single Dose Packaging Solutions

## Expanding Through Automation

- Semi-Automated Fillers and Sealers
- Full-Automated Single Dose Automation

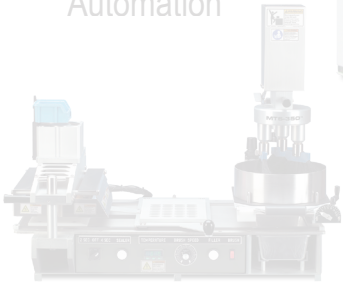

## The Next Step

- Handpacking with Heat Seal Single Dose Packaging



## Getting Started

- Handpacking with Cold Seal Single Dose Packaging



# The Next Step in Single Dose Packaging

## Heat Seal Accessories

### Paddles / Standard Paddles

#### Item # 651-32

30/31/32 Dose 2-Up  
Paddle 5/8" thick



#### Item # 651-31

30/31/32 Dose  
Do Not Use With  
Gemini 7/8" thick



#### Item # 651-62

60/62 Dose 2-Up  
Paddle 5/8" thick

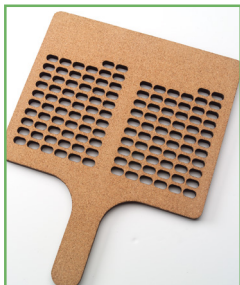

#### Item # 651-92

90 Dose 2-Up Paddle  
5/8" thick

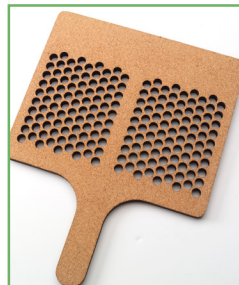

#### Item # 651-94

Unit Dose 2-Up Paddle  
5/8" thick



#### Item # 651-37

30 Mini Control 4-Up  
Paddle 5/8" thick

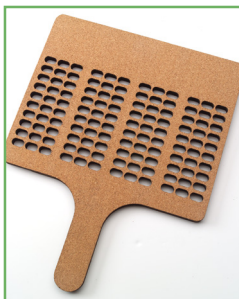

#### Item # 653-32

30/31/32 Dose 3-Up  
Paddle 5/8" thick



#### Item # 653-33

60/62 Dose 3-Up  
Paddle 5/8" thick

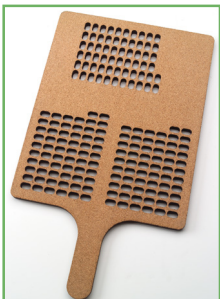

#### Item # 653-34

90 Dose 3-Up Paddle  
5/8" thick



#### Item # 653-35

Unit Dose 3-Up Paddle  
5/8" thick



#### Item # UD-612

18" Deep x 6.25" Wide x 8" Tall,  
25/Case

#### Item# UD-613

12" Deep x 6.25" Wide x 8" Tall  
Bin Boxes, 25/Case



### Miscellaneous Cards

Item #670-01,  
100/Box

**Product Inventory Card**

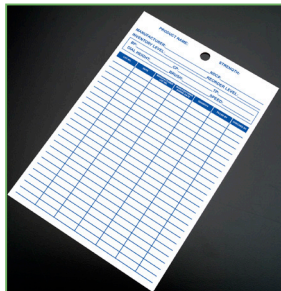

Item #670-06-US,  
250/Box

**Patient Divider Card**



Item #671-04,  
200/Box

**Locator Card**



# Next Step in Single Dose Packaging

## Automated Sealers

### Autogen™

The premier all electric, (no air required) heat sealer. Simply plug the Autogen™ into any standard 110 volt outlet to begin operation. The Autogen sets new industry standards for automated sealers - helping the pharmacy maintain operational efficiencies.

The Autogen's 500 pounds of sealing force allows for a 4 second seal on blister cards and a 2 second seal on unit dose foil and blisters. Its compact design frees up valuable pharmacy counter space. All timing functions are controlled via PLC (Programmable Logic Controller) to provide consistent quality sealing.

### Benefits

- Electrically operated system, no compressed air required
- Accommodates 5/8" thick paddle for standard 6" x 9" punch cards and 7/8" thick paddle for SureMed by Omnicell multimed blister cards
- Safe, easy, two hand operation to activate sealing mechanism
- Eliminates pressure variants associated with manual sealing equipment
- Precision designed and CE compliant components for hassle free, reliable operation
- Easy access for cleaning of heat plate if needed
- Unit is shipped complete. All settings are pre-programmed

### Features

- Provides over 500 pounds of sealing force
- Whisper quiet operation
- Air flow design creates lower heated air emissions
- Rugged stainless steel /anodized aluminum construction
- Adjustable time and temperature controls
- Removable, height adjusting base plate
- Dual timer for unit dose and blister card sealing
- Includes 1 standard configuration "Blister Card Paddle"

### Specifications

- **Height:** 13"
- **Width:** 14-1/8"
- **Depth:** 23"
- **Weight:** 65 lbs
- **Electrical:** 110 VAC, 9 A
- **Compressed Air:** None Required
- **Sealing Time:** Adjustable: Standard Punch Card / 4 seconds, Unit Dose / 2 seconds
- **Temperature Range:** 90° - 300° F
- **Service Contracts:** Annual service contracts are available

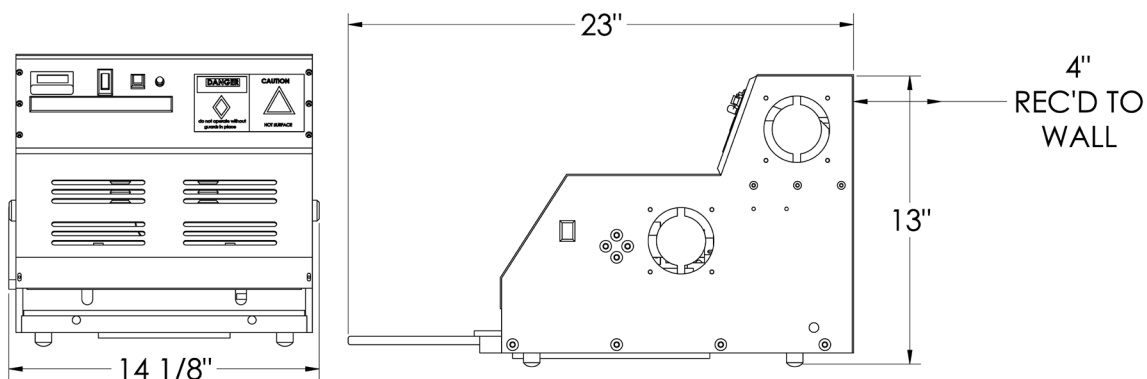

# The Next Step in Single Dose Packaging

## Standard & Amber Heat Seal Blisters

Small

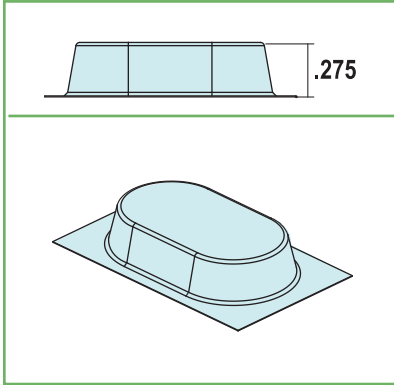

Medium

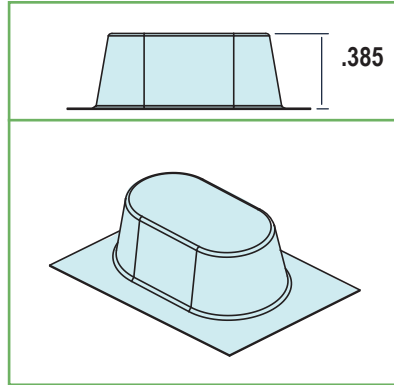

Large

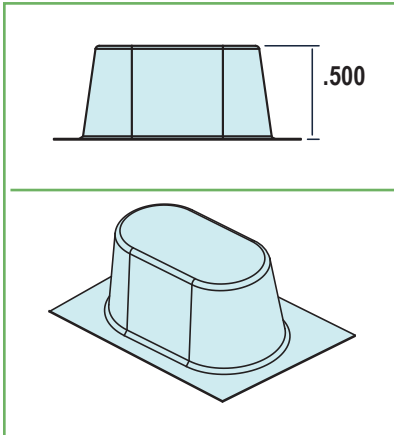

Extra Large

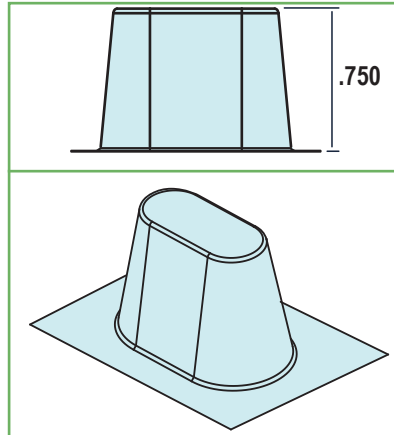

# The Next Step in Single Dose Packaging

## Handpacking with SureMed by Omnicell Heat Seal Cards

**Standard Heat Seal Cards:** Omnicell manufactures a wide range of blister card systems.

### 30-Day, 500/Box Item #300-07

**Coordinating Blisters – Standard, 1,000/Box**

Item No.	Description	
200-27	Small	
200-28	Medium	(250 Pack Available)
200-30	Large	(250 Pack Available)
200-51*	Extra Large	
203-29	Small Amber	
203-32	Medium Amber	
203-34	Large Amber	

\*Blister requires special paddle. Not to be used in Gemini.

**Recommended Accessories:**

- Paddle #651-32
- Paddle for XL Blisters #651-31

**Refer to Page 39 for Blister Sizes**

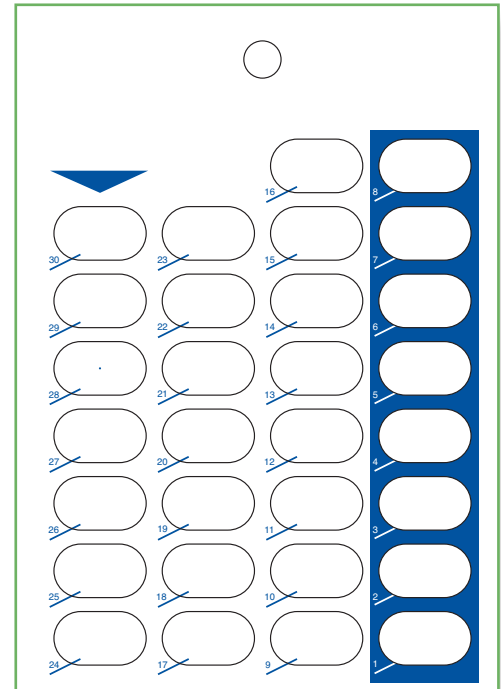

### 30-Day, 500/Box Item #300-07DC

**Coordinating Blisters – Standard, 1,000/Box**

**Refer to Page 39 for Sizes**

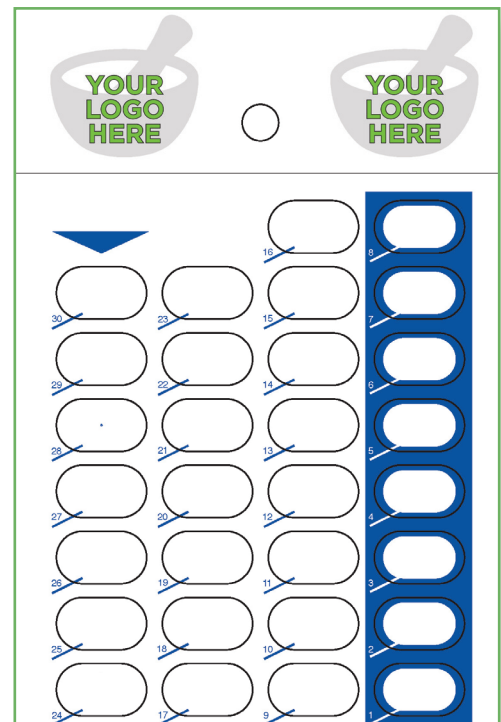



# The Next Step in Single Dose Packaging

## Handpacking with SureMed by Omnicell Heat Seal Cards

31-Day, 500/Box      Item #300-25

**Coordinating Blisters – Standard, 1,000/Box**

Item No.	Description	
200-31	Small	
200-32	Medium	(250 Pack Available)
200-34	Large	(250 Pack Available)
200-52*	Extra Large	
203-30	Small Amber	
203-31	Medium Amber	
203-33	Large Amber	

\*Blister requires special paddle. Not to be used in Gemini.

*Recommended Accessories:*

- Paddle #651-32
- Paddle for XL Blisters #651-31

**Refer to Page 39 for Blister Sizes**

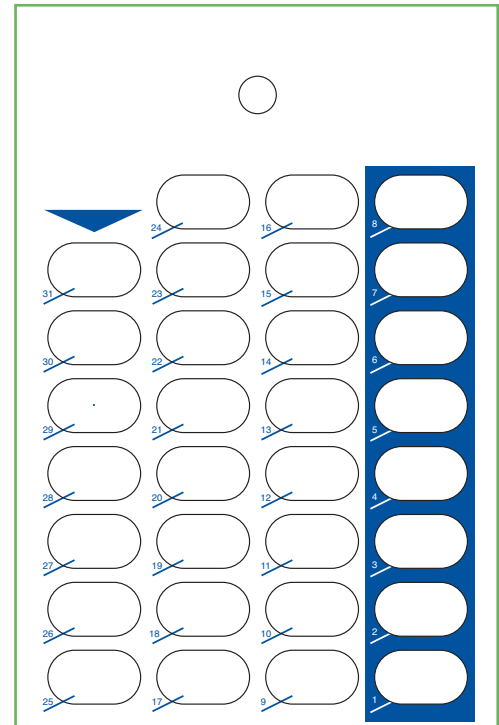

31-Day, 500/Box      Item #300-25DC

**Coordinating Blisters – Standard, 1,000/Box**

**Refer to Page 39 for Sizes**

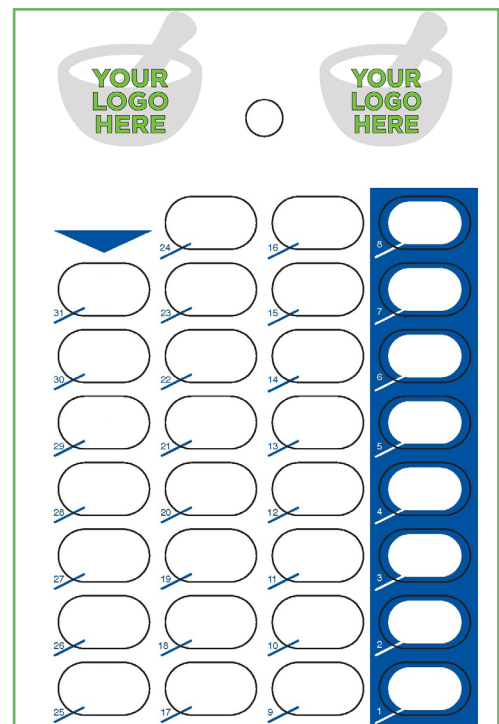



# The Next Step in Single Dose Packaging

## Handpacking with SureMed by Omnicell Heat Seal Cards

### 31-Day, 500/Box      Item #300-16

#### Coordinating Blisters – Standard, 1,000/Box

Item No.	Description	
200-31	Small	
200-32	Medium	(250 Pack Available)
200-34	Large	(250 Pack Available)
200-52*	Extra Large	
203-30	Small Amber	
203-31	Medium Amber	
203-33	Large Amber	

\*Blister requires special paddle. Not to be used in Gemini.

#### Recommended Accessories:

- Paddle #651-32
- Paddle for XL Blisters #651-31

**Refer to Page 39 for Blister Sizes**

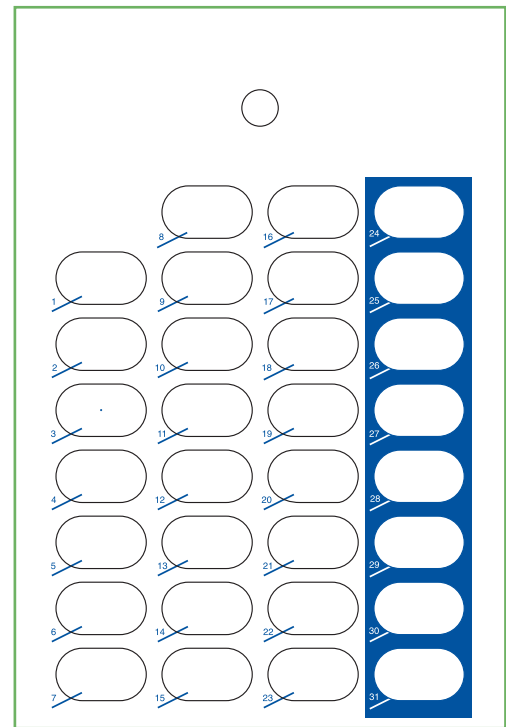

### 32-Day, 500/Box      Item #300-12

#### Coordinating Blisters – Standard, 1,000/Box

Item No.	Description
200-35	Small
200-36	Medium
200-38	Large

#### Recommended Accessories:

- Paddle #651-32

**Refer to Page 39 for Blister Sizes**

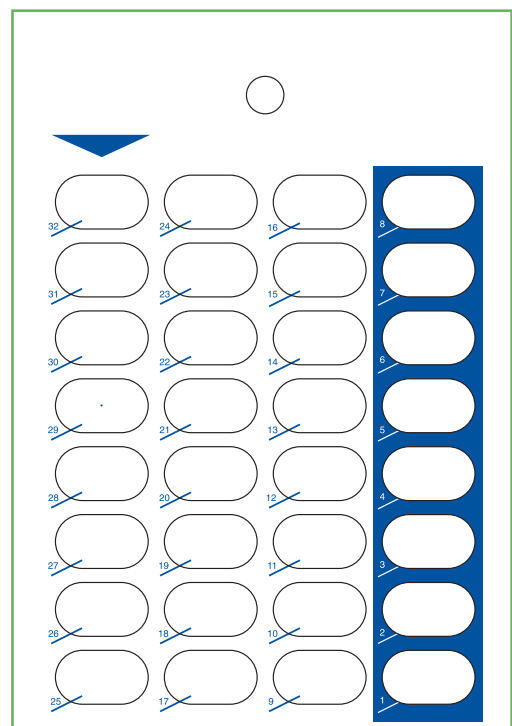

# The Next Step in Single Dose Packaging

## Handpacking with SureMed by Omnicell Heat Seal Cards

60-Day, 500/Box Item #300-09

Coordinating Blisters – Standard, 1,000/Box

Item No.	Description
200-60	60-Day (250 Pack Available)
203-60	60-Day Amber

Recommended Accessories:

- Paddle #651-62

Refer to Page 39 for Blister Sizes

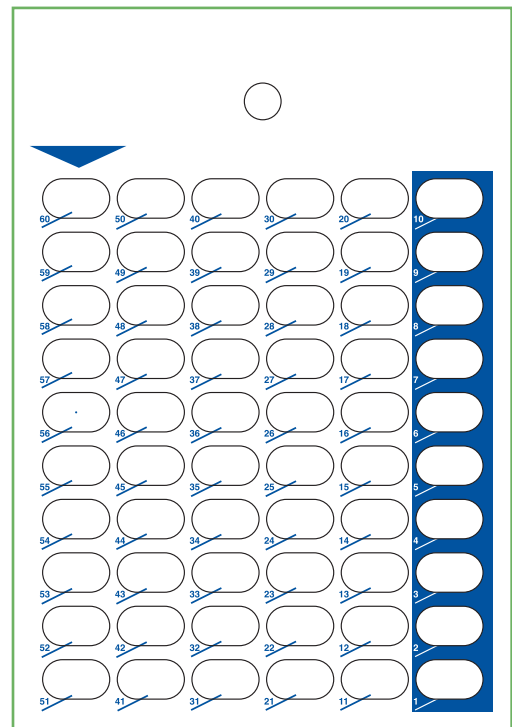

60-Day, 500/Box Item #300-09DC

Coordinating Blisters – Standard, 1,000/Box

Refer to Page 39 for Blister Sizes

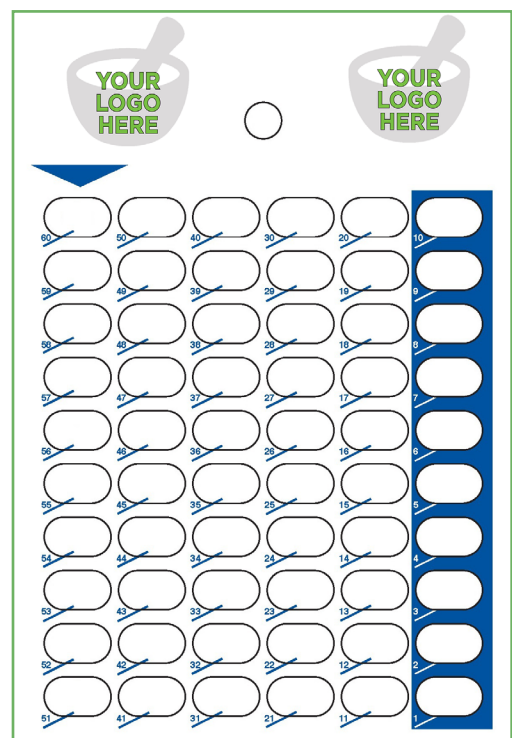

# The Next Step in Single Dose Packaging

## Handpacking with SureMed by Omnicell Heat Seal Cards

### 62-Day, 500/Box      Item #300-27

#### Coordinating Blisters – Standard, 1,000/Box

Item No.	Description	
200-23	62-Day	(250 Pack Available)
203-25	62-Day Amber	

#### Recommended Accessories:

- Paddle #651-62

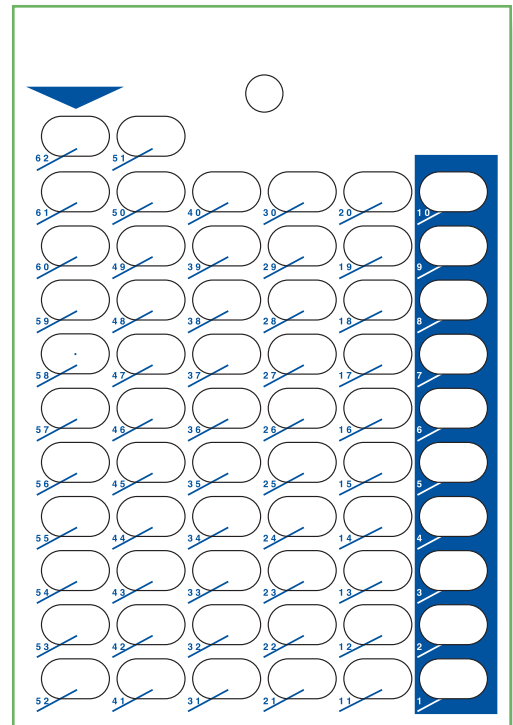
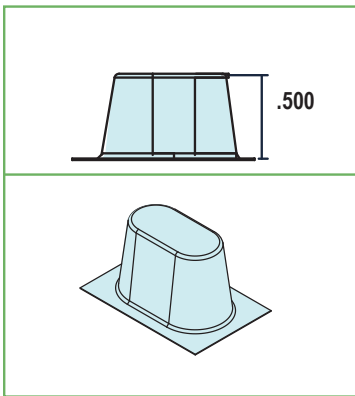

### 90-Day, 500/Box      Item #300-11

#### Coordinating Blisters – Standard, 1,000/Box

Item No.	Description	
200-24	90-Day	(250 Pack Available)
203-26	90-Day, Amber	

#### Recommended Accessories:

- Paddle #651-92

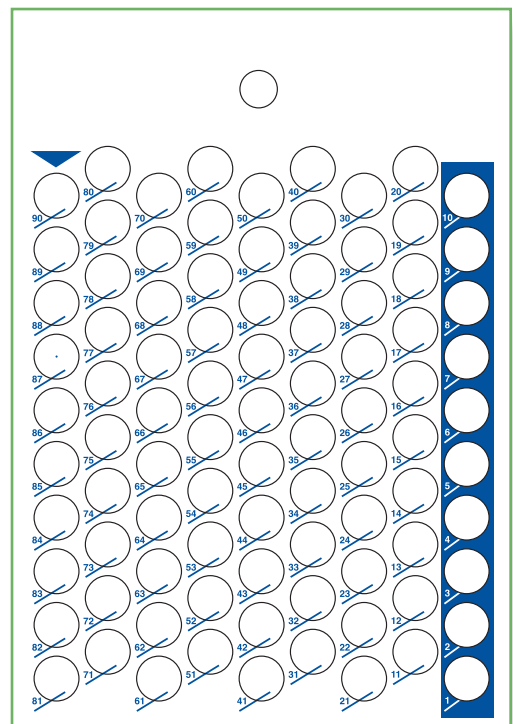
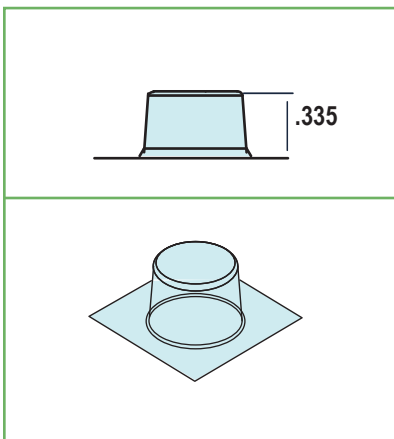

# The Next Step in Single Dose Packaging

## Handpacking with SureMed by Omnicell One-Piece Heat Seal Cards

**One-Piece Cards:** A variety of our standard heat seal cards are also available with blisters already adhered to the card.

### 30-Day One-Piece Cards, 250/Box

**Choose from these Standard Blisters:**

<i>Item No.</i>	<i>Description</i>
300-77-B30M	30-Day, Medium Blister
300-77-B30OV	30-Day, Large Blister
300-77-A30OV	30-Day, Large Amber Blister

*Recommended Accessories:*

- Paddle #651-32

**Refer to Page 39 for Blister Sizes**

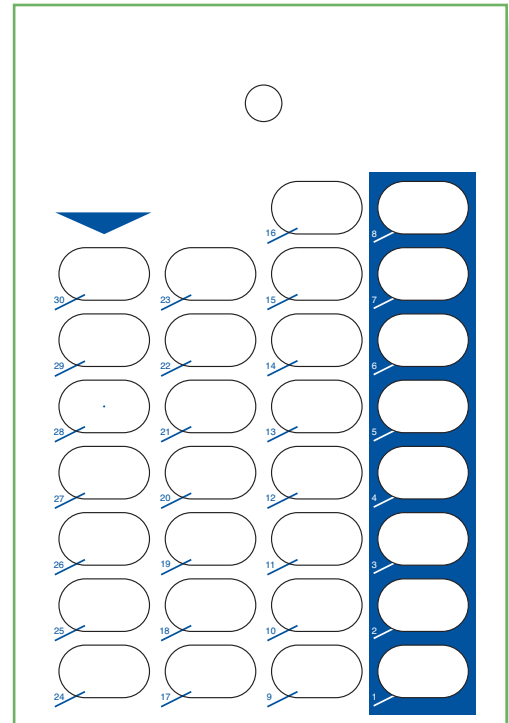

### 31-Day One-Piece Cards, 250/Box

**Choose from these Standard Blisters:**

<i>Item No.</i>	<i>Description</i>
300-78-B31S	31-Day, Small Blister
300-78-B31M	31-Day, Medium Blister
300-78-B31OV	31-Day, Large Blister
300-78-A31OV	31-Day, Large Amber Blister

*Recommended Accessories:*

- Paddle #651-32

**Refer to Page 39 for Blister Sizes**

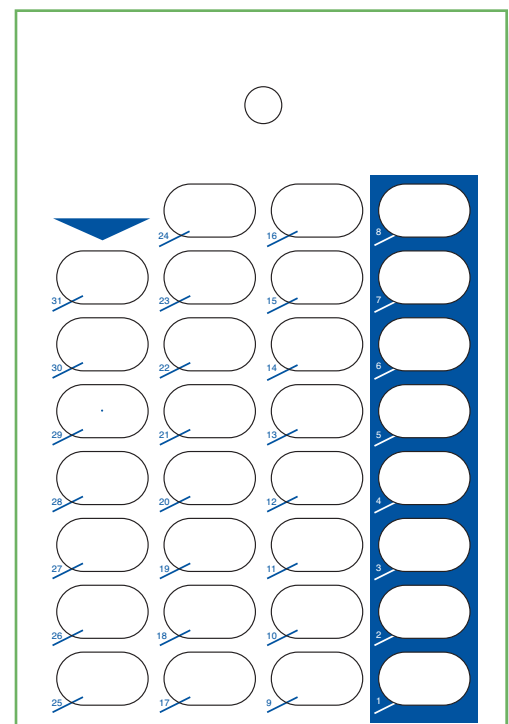

# The Next Step in Single Dose Packaging

## Handpacking with SureMed by Omnicell One-Piece Heat Seal Cards

### 32-Day One-Piece Cards, 250/Box

Choose from these Standard Blisters:

Item No.	Description
300-79-B32OV	32-Day, Large Oval Blister

Recommended Accessories:

- Paddle #651-32

Refer to Page 39 for Blister Sizes

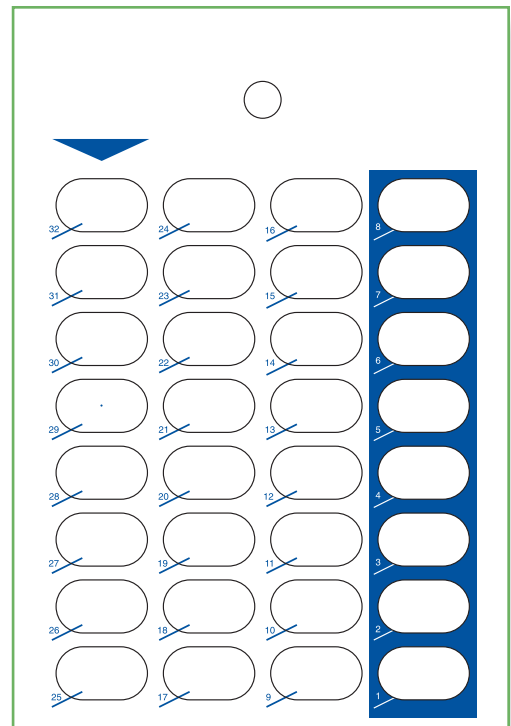

### 60-Day One-Piece Cards, 250/Box

Choose from these Standard Blisters:

Item No.	Description
300-80-B60	60-Day Blister

Recommended Accessories:

- Paddle #651-62

Refer to Page 39 for Blister Sizes

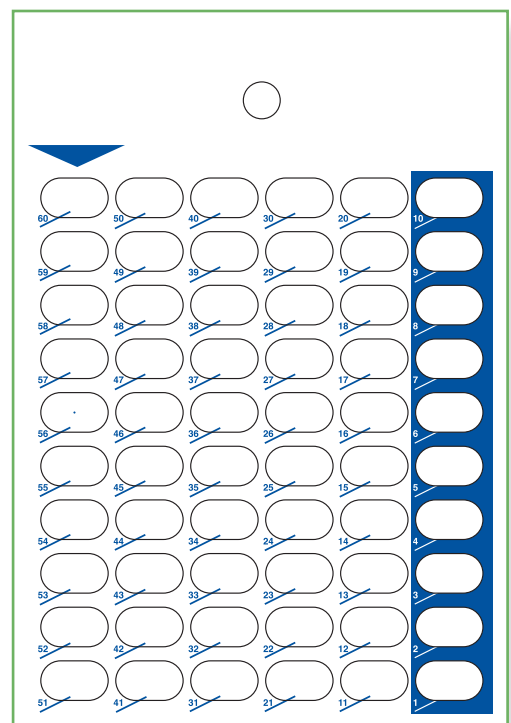

# The Next Step in Single Dose Packaging

## Handpacking with SureMed by Omnicell One-Piece Heat Seal Cards

### 62-Day One-Piece Cards, 250/Box

Choose from these Standard Blisters:

Item No.	Description
300-81-B62	62-Day, Blister

Recommended Accessories:

- Paddle #651-62

Refer to Page 39 for Blister Sizes

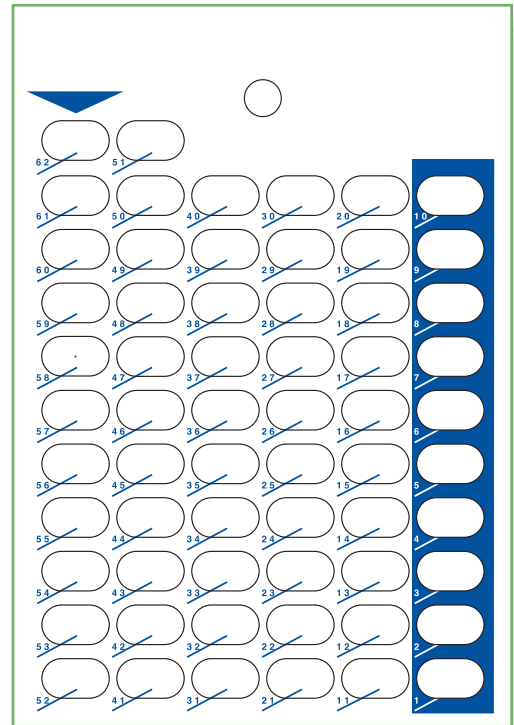

### 90-Day One-Piece Cards, 250/Box

Choose from these Standard Blisters:

Item No.	Description
300-82-B90	90-Day, Blister

Recommended Accessories:

- Paddle #651-92

Refer to Page 39 for Blister Sizes

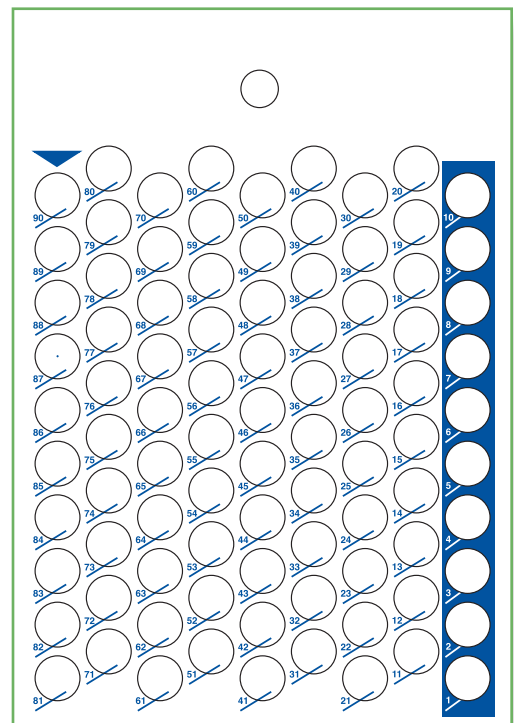

# The Next Step in Single Dose Packaging

## Select Seal™ & Med Cards

30-Day, 500/Box      Item #300-13  
Select Seal

**Coordinating Blisters – Unit Dose – Standard, 1,000/Box**

Item No.	Description
201-10	Small
201-11	Medium
201-13	Large
203-16	Large Amber
201-13XL	Extra Large (Does not nest)

*Foil sold separately. See pages 115-116.*

*Note: Standard Unit Dose Blisters are produced 32 per sheet (4x8).*

*Select sizes are available in 14, 28, 30 and 31 dose.*

**Refer to Page 39 for Blister Sizes**

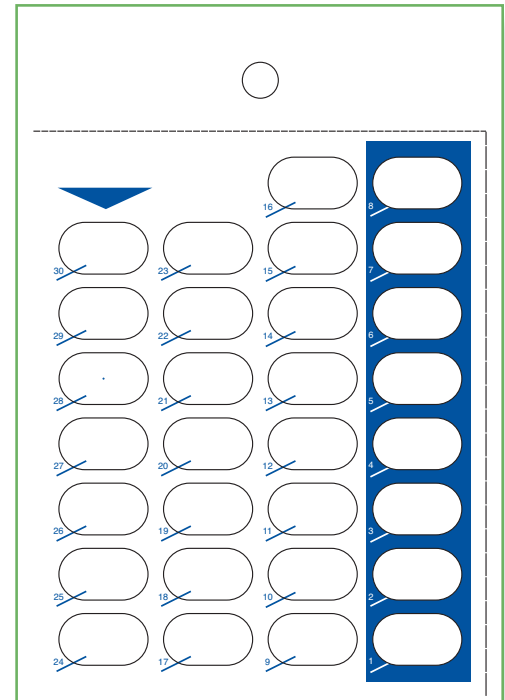

30-Day, 500/Box      Item #300-13DC  
Select Seal

**Coordinating Blisters – Unit Dose – Standard, 1,000/Box**

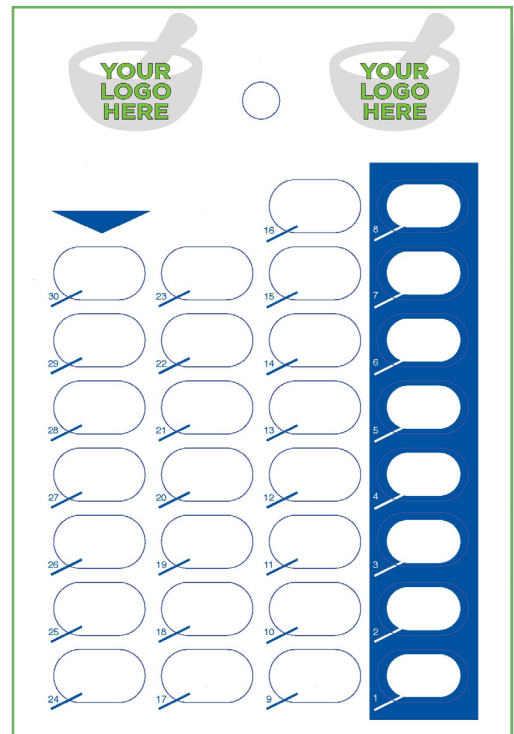



# The Next Step in Single Dose Packaging

## Select Seal™ & Med Cards

### 31-Day, 500/Box      Item #300-14

#### Select Seal

#### Coordinating Blisters – Unit Dose – Standard, 1,000/Box

Item No.	Description
201-10	Small
201-11	Medium
201-13	Large
203-16	Large Amber
201-13XL	Extra Large (Does not nest)

Foil sold separately. See pages 115-116.

Note: Standard Unit Dose Blisters are produced 32 per sheet (4x8).

Select sizes are available in 14, 28, 30 and 31 dose.

**Refer to Page 39 for Blister Sizes**

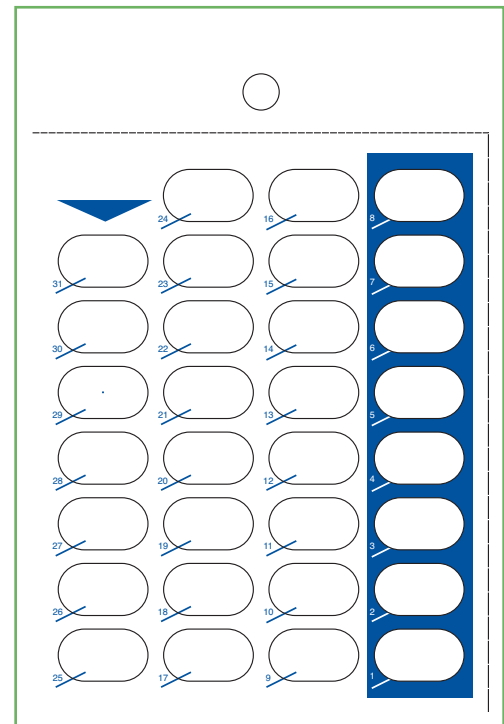

### 32-Day, 500/Box      Item #300-15

#### Select Seal

#### Coordinating Blisters – Unit Dose, 1,000/Box

Item No.	Description
201-10	Small
201-11	Medium
201-13	Large
203-16	Large Amber
201-13XL	Extra Large (Does not nest)

Foil sold separately. See pages 115-116.

**Refer to Page 39 for Blister Sizes**

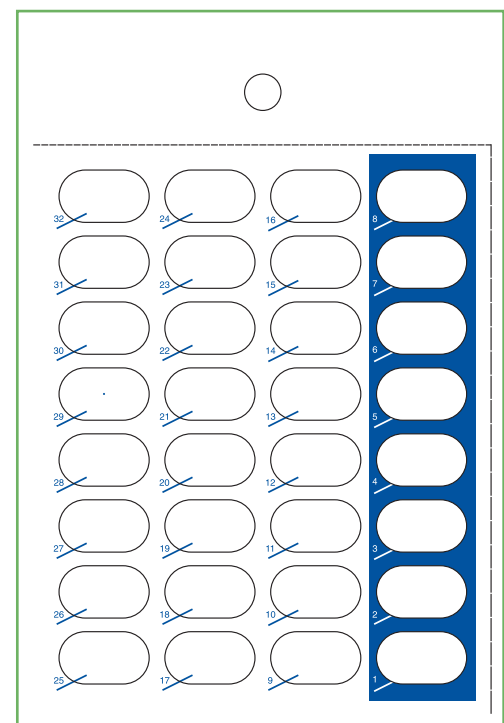

# The Next Step in Single Dose Packaging

## Select Seal™ & Med Cards

### 7-Day/14-Day, 500/Box Item #300-32

#### Select Seal

#### Coordinating Blisters – Unit Dose, 1,000/Box

Item No.	Description
201-05	Large-14 Count

Foil sold separately. See pages 115-116.

**Refer to Page 39 for Blister Sizes**

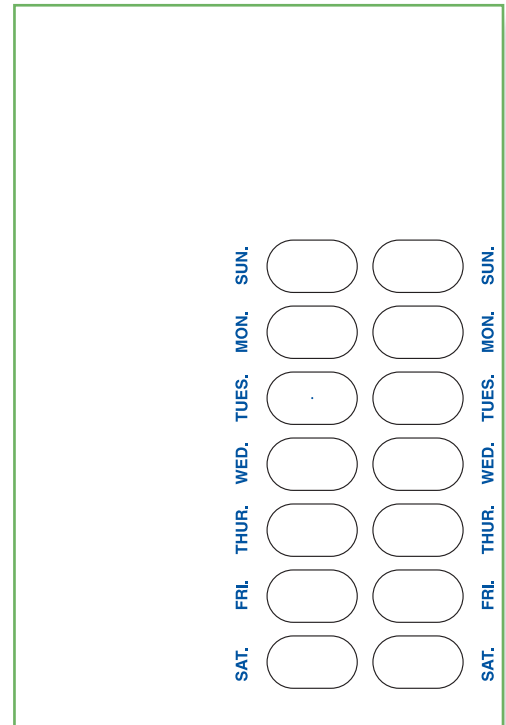

### 30-Day, 500/Box Item #300-73

#### Med Card

#### Coordinating Blisters – Unit Dose, 1,000/Box

Item No.	Description
201-10	Small
201-11	Medium
201-13	Large
203-16	Large Amber
201-13XL	Extra Large (Does not nest)

Foil sold separately. See pages 115-116.

\* Available in 30 count.

**Refer to Page 39 for Blister Sizes**

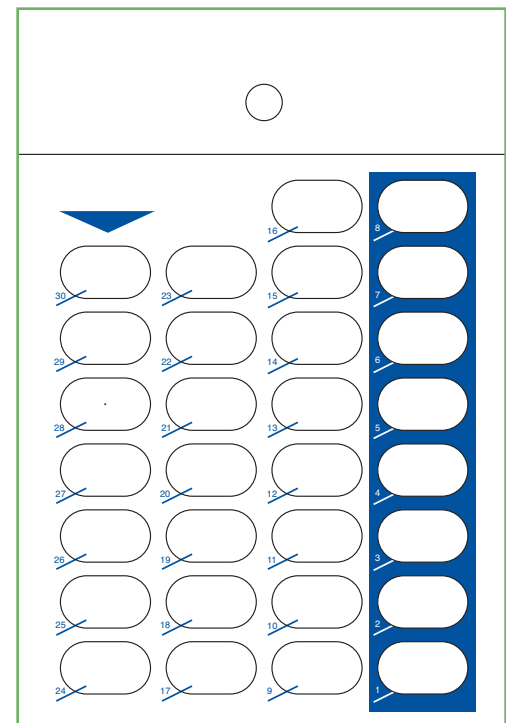

#### Cold Seal Version Available Item #300-74

# The Next Step in Single Dose Packaging

## Select Seal™ & Med Cards

31-Day, 500/Box      Item #300-70  
Med Card

**Coordinating Blisters – Unit Dose, 1,000/Box**

Item No.	Description
201-10	Small
201-11	Medium
201-13	Large
203-16	Large Amber
201-13XL	Extra Large (Does not nest)

*Foil sold separately. See pages 115-116.*

*\*Available in 31 count.*

**Refer to Page 39 for Blister Sizes**

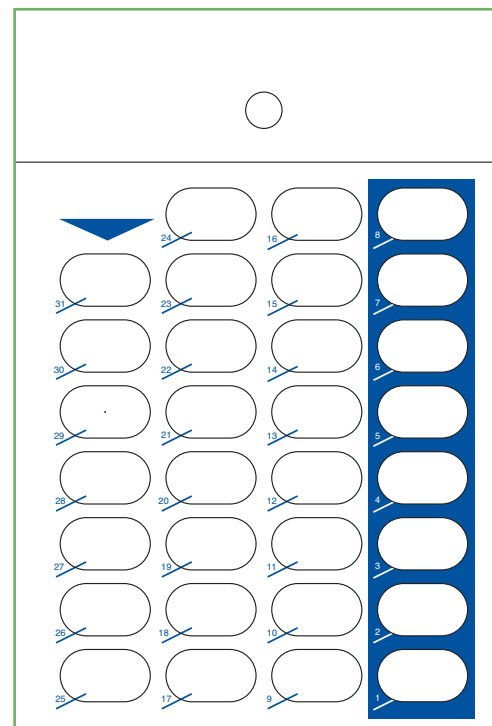

31-Day, 500/Box      Item #300-71  
Med Card - Calendar

**Coordinating Blisters – Unit Dose, 1,000/Box**

Item No.	Description
201-10	Small
201-11	Medium
201-13	Large
203-16	Large Amber
201-13XL	Extra Large (Does not nest)

*Foil sold separately. See pages 115-116.*

*\*Available in 31 count.*

**Refer to Page 39 for Blister Sizes**

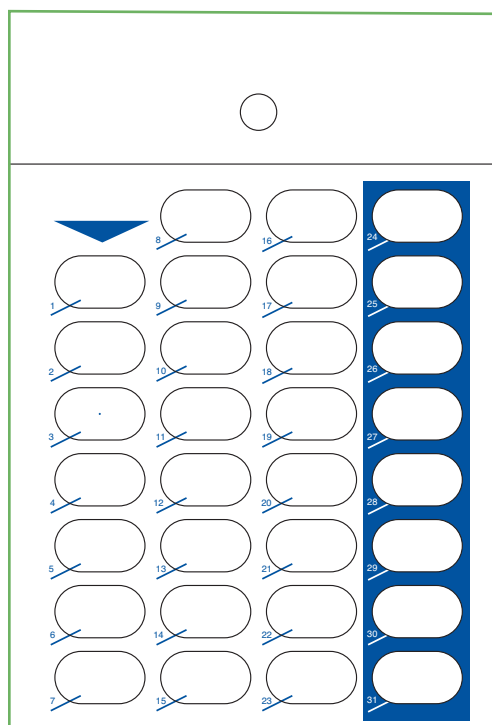

# The Next Step in Single Dose Packaging

## Select Seal™ & Med Cards

32-Day, 500/Box      Item #300-72  
Med Card

### Coordinating Blisters – Unit Dose, 1,000/Box

<i>Item No.</i>	<i>Description</i>
201-10	Small
201-11	Medium
201-13	Large
203-16	Large Amber
201-13XL	Extra Large (Does not nest)

*\*Foil sold separately. See pages 115-116.*

**Refer to Page 39 for Blister Sizes**

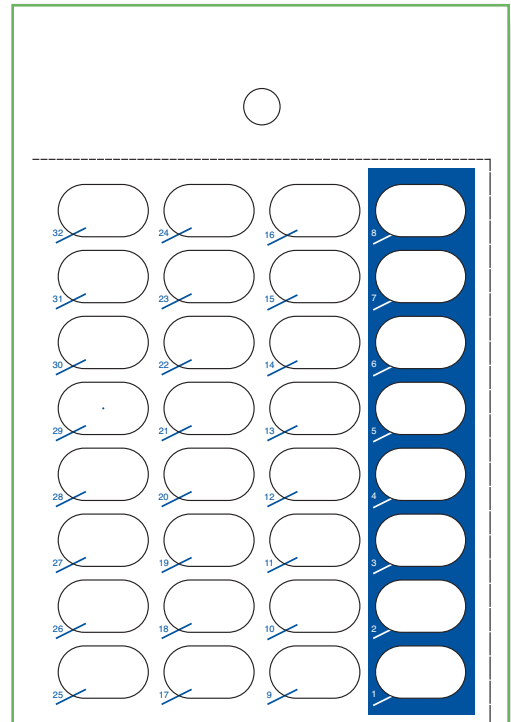

# The Next Step in Single Dose Packaging

## Control Cards

**Control Cards:** Specifically designed for the identification of controlled drugs. The smaller size and red color help differentiate it from other blister cards. The card provides easy identification, and when sealed with Omnicell packaging equipment, provides a consistent, durable seal.

### 30-Day Mini, 500/Box Item #300-67

**Coordinating Blisters, 1,000/Box** – (same dimensions as 60/62 blisters)

Item No.	Description
200-22	30 Mini
200-21	30 Mini Amber

**Finished Card Size - 9"x3"**

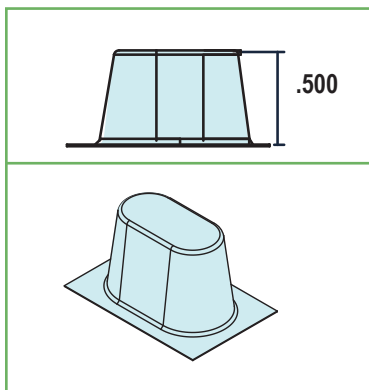

**30 Day Mini Blister**

*Recommended Accessories:*

- Paddle #651-32

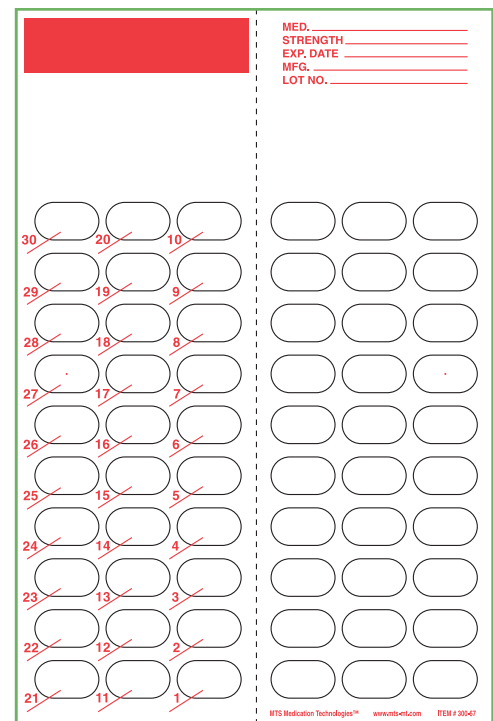

# The Next Step in Single Dose Packaging

## Red Cards

**Red Cards:** Omnicell manufactures a range of Red Standard Cards as well as Red Narrow Cards. Our narrow cards are 5-5/8" in width. Standard width is 6". These cards accommodate different med cart styles and come in 31, 62 & 90 day formats.

### 31-Day, 500/Box

### Item #302-15

#### Coordinating Blisters – Standard, 1,000/Box

Item No.	Description
200-31	Small
200-32	Medium (250 Pack Available)
200-34	Large (250 Pack Available)
200-52*	Extra Large
203-30	Small Amber
203-31	Medium Amber
203-33	Large Amber

\*Blister requires special paddle. Not to be used in Gemini.

#### Recommended Accessories:

- Paddle #651-32
- Paddle for XL Blisters #651-31

Refer to Page 39 for Blister Sizes

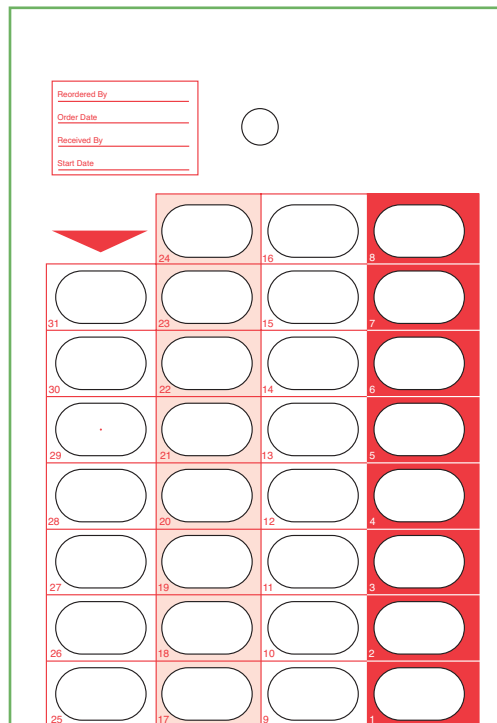

### 62-Day, 500/Box

### Item #302-11

#### Coordinating Blisters – Standard, 1,000/Box

Item No.	Description
200-23	62-Day (250 Pack Available)
203-25	62-Day, Amber

#### Recommended Accessories:

- Paddle #651-62

Refer to Page 39 for Blister Sizes

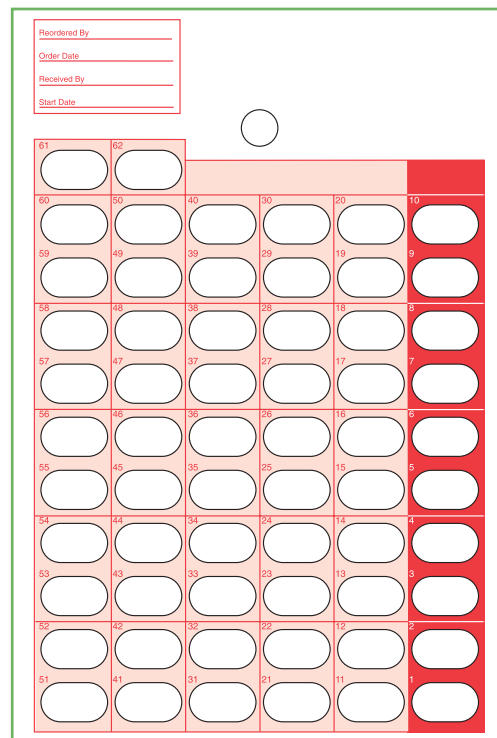

# The Next Step in Single Dose Packaging

## Red Cards

### 31-Day Narrow, 500/Box Item #302-14

#### Coordinating Blisters – Standard, 1,000/Box

Item No.	Description
200-31	Small
200-32	Medium (250 Pack Available)
200-34	Large (250 Pack Available)
200-52*	Extra Large
203-30	Small Amber
203-31	Medium Amber
203-33	Large Amber

\*Blister requires special paddle. Not to be used in Gemini.

#### Recommended Accessories:

- Paddle #651-32
- Paddle for XL Blisters #651-31

**Refer to Page 39 for Blister Sizes**

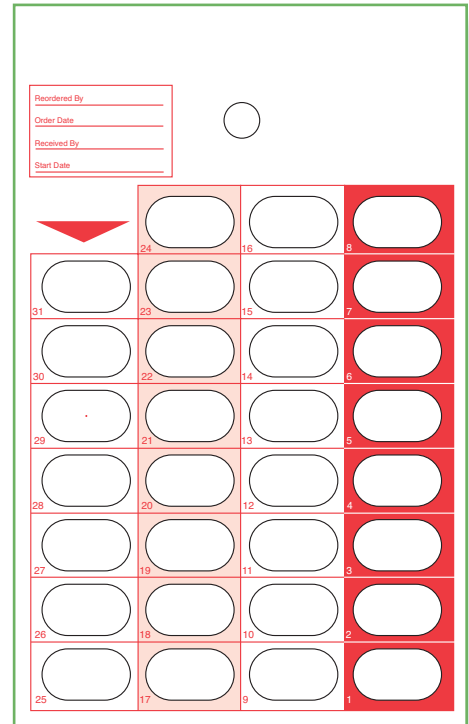



# The Next Step in Single Dose Packaging

## Trap Door Cards

**Trap Door Cards:** Provides an extra layer of cardboard over the foil to ensure an added level of tamper evidence.

### 30-Dose, 500/Box Item #300-61

#### Coordinating Blisters – Standard, 1,000/Box

Item No.	Description	
200-27	Small	
200-28	Medium	(250 Pack Available)
200-30	Large	(250 Pack Available)
200-51*	Extra Large	
203-29	Small Amber	
203-32	Medium Amber	
203-34	Large Amber	

\*Blister requires special paddle. Not to be used in Gemini.

#### Recommended Accessories:

- Paddle #651-32
- Paddle for XL Blisters #651-31

Refer to Page 39 for Blister Sizes

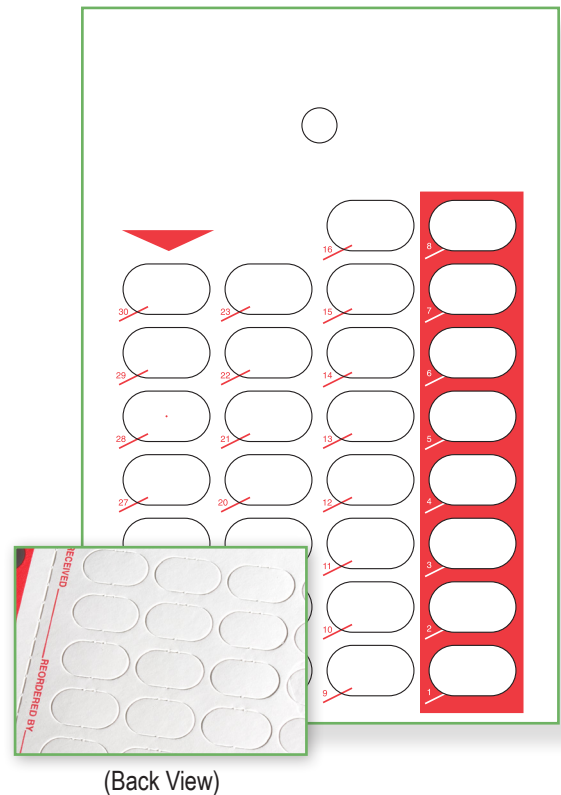

### 60-Dose, 500/Box Item #300-63

#### Coordinating Blisters – Standard, 1,000/Box

Item No.	Description	
200-60	60-Day	(250 Pack Available)
203-60	60-Day, Amber	

#### Recommended Accessories:

- Paddle #651-62

Refer to Page 39 for Blister Sizes

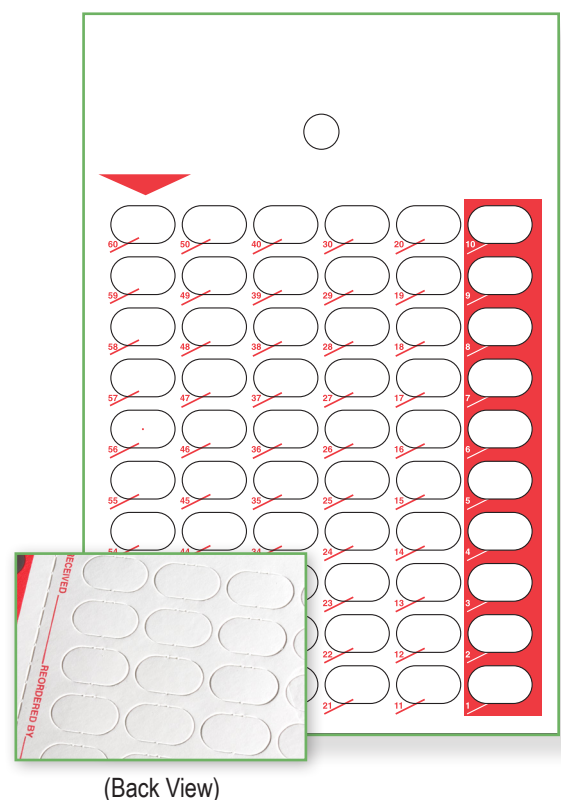

# The Next Step in Single Dose Packaging

## Mealtime Cards

**Mealtime Cards:** 31-Day calendar mealtime cards are available in various colors to visually identify morning, afternoon, evening and bedtime medication passes. A white PRN card is also available.

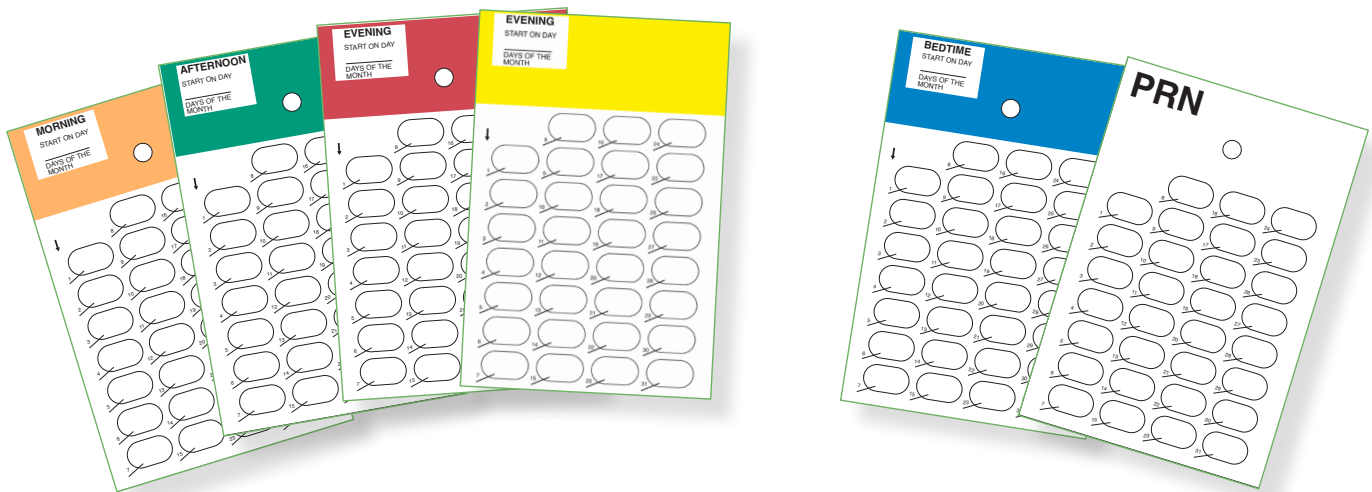

31-Day Morning (Orange), 500/Box - Item #300-43

31-Day Afternoon (Green), 500/Box - Item #300-44

31-Day Evening (Red), 500/Box - Item #300-45

31-Day Evening (Yellow), 500/Box - Item #300-45Y

31-Day Bedtime (Blue), 500/Box - Item #300-46

31-Day PRN, 500/Box - Item #300-47

Item No.	Description
200-31	Small
200-32	Medium (250 Pack Available)
200-34	Large (250 Pack Available)
200-52*	Extra Large
203-30	Small Amber
203-31	Medium Amber
203-33	Large Amber

\*Blister requires special paddle. Not to be used in Gemini.

### Recommended Accessories:

- Paddle #651-32
- Paddle for XL Blisters #651-31

**Refer to Page 39 for Blister Sizes**

# The Next Step in Single Dose Packaging

## 14/15/16 Dose Cards

**14/15/16 - Dose and Short Cycle Cards:** MTS offers a variety of reduced cycle punch cards. 14-Day cards are available in both 9" x 3", as well as 9" x 6" formats.

### 14-Day Red, 500/BX Item #300-18

**Coordinating Blisters – Unit Dose, 1,000/BX**

Item No.	Description
201-05	Large 14-Day

Refer to Page 39 for Blister Sizes

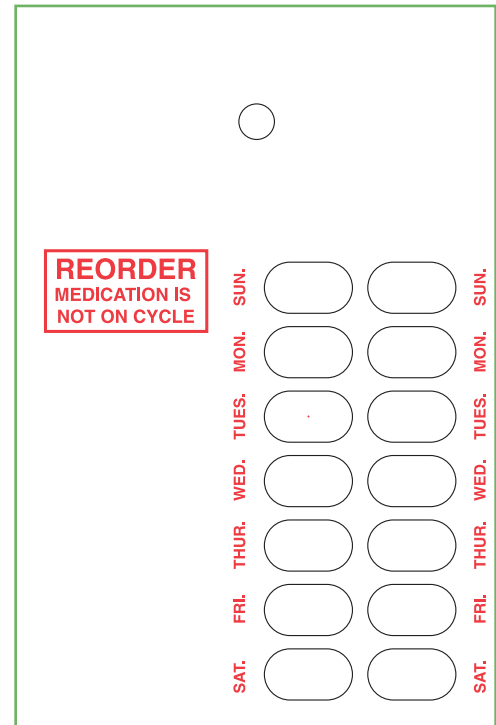

### 14-Day Blue, 500/BX Item #300-19

**Coordinating Blisters – Unit Dose, 1,000/BX**

Item No.	Description
201-05	Large 14-Day

Refer to Page 39 for Blister Sizes

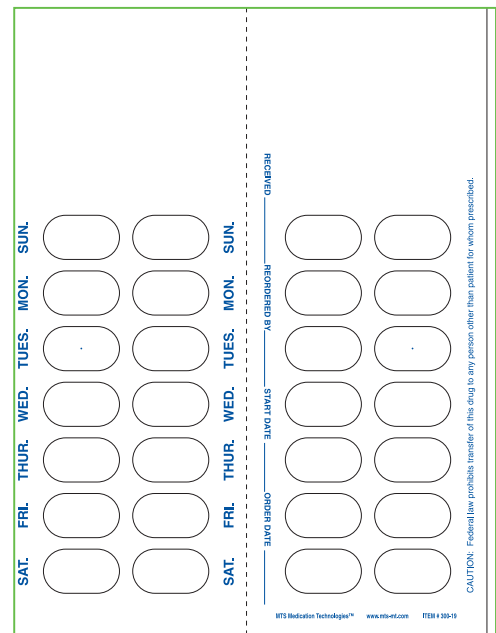

# The Next Step in Single Dose Packaging

## 14/15/16 Dose Cards

### 15-Day, 500/Box Item #300-36

#### Coordinating Blisters – Unit Dose, 1,000/Box

Item No.	Description
201-10	Small
201-11	Medium
201-13	Large
203-16	Large Amber
201-13XL	Extra Large (Does not nest)

#### Recommended Accessories:

- Paddle #651-32
- Paddle for XL Blisters #651-31

Refer to Page 39 for Blister Sizes

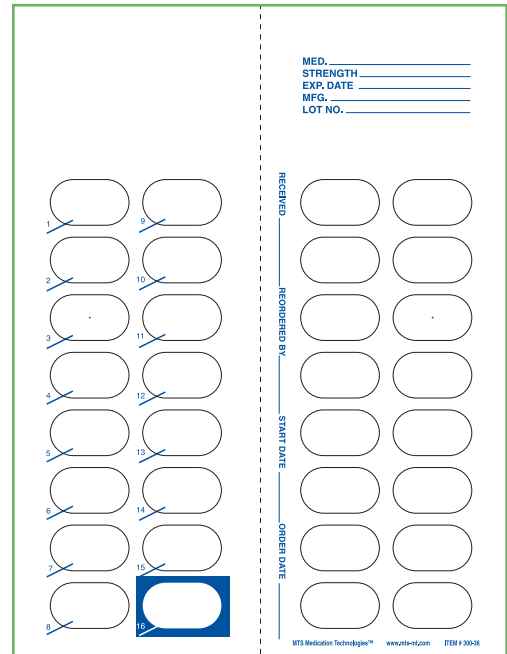

### 14-Day, 500/Box Item #314-51

#### Coordinating Blisters – Unit Dose, 1,000/Box

Item No.	Description
201-05	Large 14-Day

Also available in cold seal version (314-61), see page 36 for more details.

#### Recommended Accessories:

- Paddle #651-32
- Paddle for XL Blisters #651-31

Refer to Page 39 for Blister Sizes

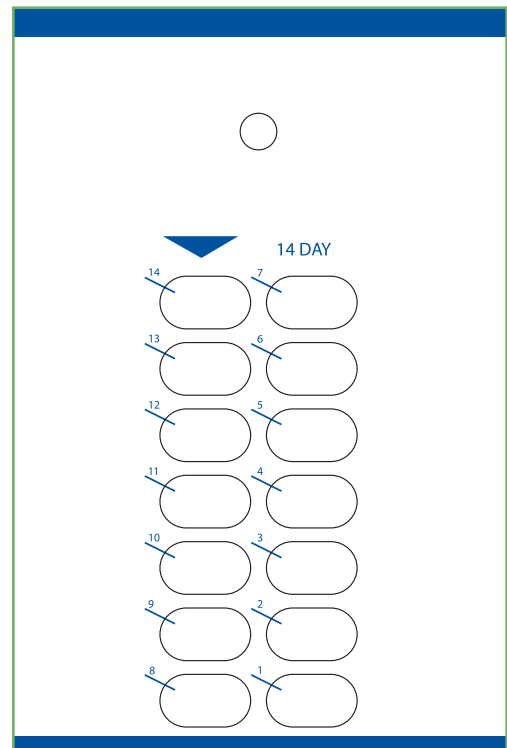

# The Next Step in Single Dose Packaging

## Miscellaneous Cards

### 28-Day Calendar, 500/Box Item #300-38

#### Coordinating Blisters – Standard, 1,000/Box

Item No.	Description
200-15	Small
200-16	Medium
200-18	Large
200-50*	Extra Large
203-16	Large Amber (Perforated)

\*Blister requires special paddle. Not to be used in Gemini.

#### Recommended Accessories:

- Paddle #651-32
- Paddle for XL Blisters #651-31

Refer to Page 39 for Blister Sizes

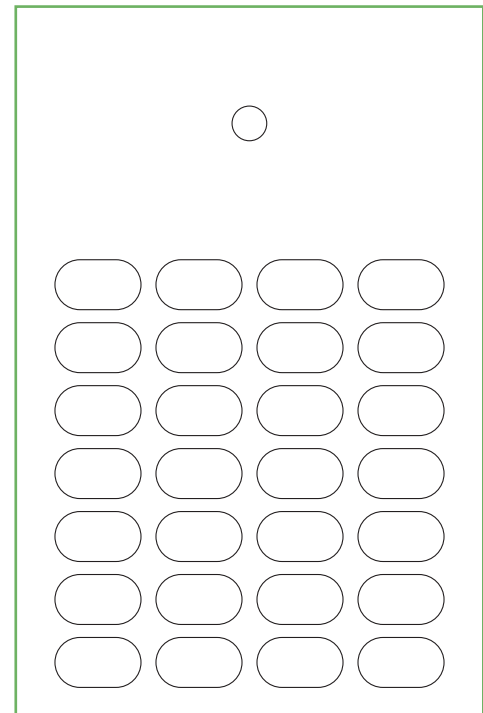

### 30-Day Blank, 500/Box Item #300-28

#### Coordinating Blisters – Standard, 1,000/Box

200-27	Small
200-28	Medium
200-30	Large
200-51*	Extra Large
203-29	Small Amber
203-32	Medium Amber
203-34	Large Amber

\*Blister requires special paddle. Not to be used in Gemini.

#### Recommended Accessories:

- Paddle #651-32
- Paddle for XL Blisters #651-31

Refer to Page 39 for Blister Sizes

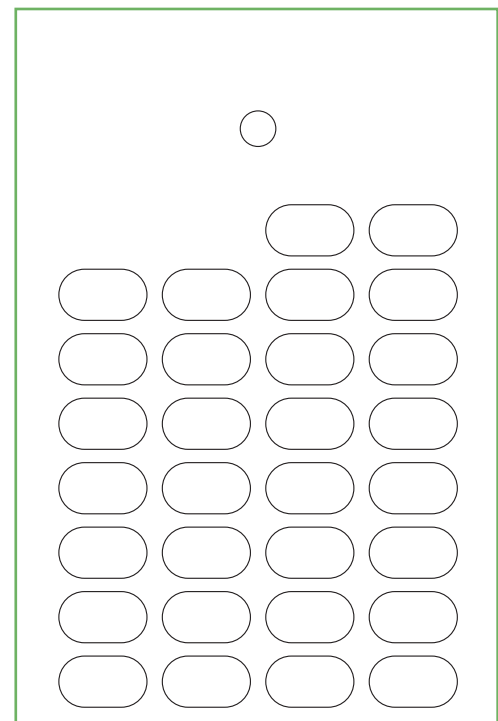

# The Next Step in Single Dose Packaging

## Miscellaneous Cards

**Miscellaneous Cards:** Omnicell offers a variety of specialty cards and systems to fit your needs.

### 7-Day/28-Dose, 500/Box Item #300-37

#### Coordinating Blisters – Standard, 1,000/Box

Item No.	Description
200-15	Small
200-16	Medium
200-18	Large
200-50*	Extra Large
203-16	Large Amber (Perforated)

\*Blister requires special paddle. Not to be used in Gemini.

#### Recommended Accessories:

- Paddle #651-32
- Paddle for XL Blisters #651-31

**Refer to Page 39 for Blister Sizes**

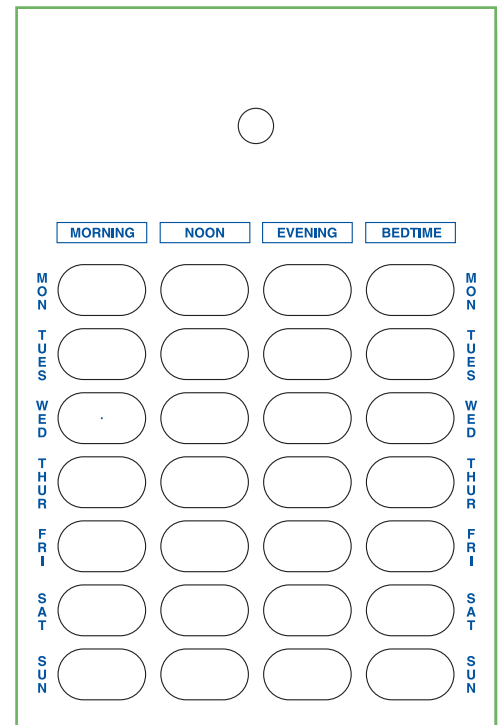

# Opti-Pak™ System

A disposable color-coded compliance package. The blister cards are available in 7/8 dose and 14/16 dose formats and are compatible with 3" medication cart drawers. The Opti-Pak is both tamper-evident and hygienic. The ability to automate the filling and sealing of the Opti-Pak product makes this system a viable compliance packaging solution for the pharmacy, home and resident.

## Automation

Opti-Pak can be packaged using Omnicell Automation:

MTS 350™ ..... see page 76

OnDemand® AccuFlex® ..... see page 79

## Blisters

Opti-Pak comes with a standard blister.

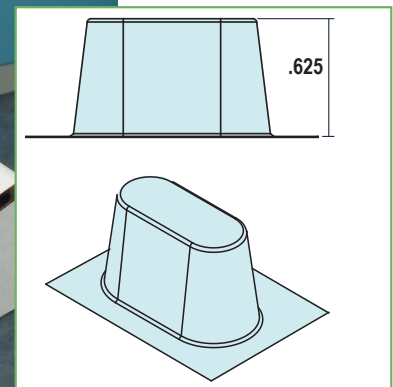

**Opti-Pak Blister**



### Cards & Blisters, 1,000/Box

Item No.	Description	Blister
301-08	8/16-Day Heat Seal, Days of the Week	204-08
301-09	8/16-Day PRN Heat Seal, #'s 1-16	204-08

**Recommended Accessories:**

- Paddle #651-44

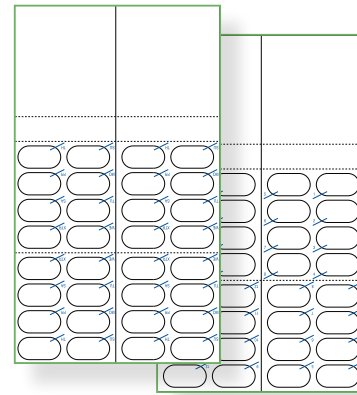

### Storage Container, 100/Box

Item No.	Description
671-01	For 14/16-Day Cards



### Item # 651-44

Opti-Pak Paddle  
5/8" thick

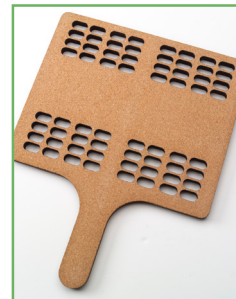

### Item # L-301-B1 thru L-301-B8 Op- ti-Pak - Color Coded Rx Labels

Size: 1 1/2" x 1"  
Paper: Single Ply  
Finish: Fanfold / 5,000/Box

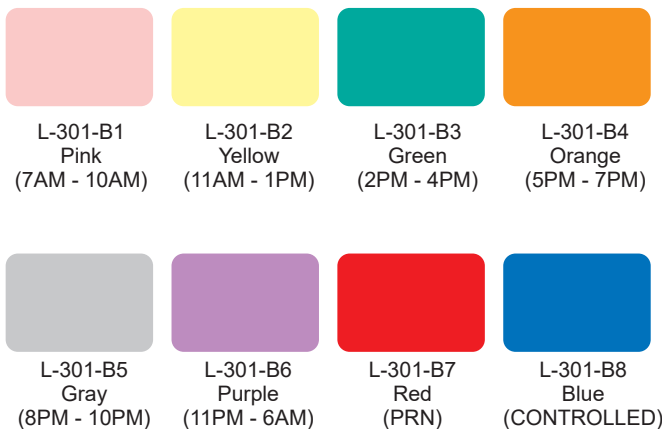

### Item # L-301-KIT Opti-Pak - Time Pass Kit All Colors

Size: 1 1/2" x 1"  
Paper: Single Ply  
Finish: Fanfold / 1,000/Color = 8,000/Box



# Unit Dose

With the Omnicell Unit Dose foil labeling system, you can efficiently print, package and seal medications to be dispensed in varying quantities (from single dose to short-cycle to 30-day regimen). Along with providing the flexibility to package medications in multiple systems, Omnicell Unit Dose enables pharmacies to reduce waste, minimize labor, and control inventory.

## Centralize Pre-Pack Inventory:

Omnicell Unit Dose provides the option to create a centralized inventory of prepackaged foil and blister for use in reclaimable and non-reclaimable blister cards, unit dose box, and E-kits for greater economies of scale.

## Return & Reuse:

When used together, Omnicell Unit Dose and SelectSeal™ blister cards allow for the reclamation of unused medication in states where the return and reuse of unused medication is permissible. Med Cards are used to easily repackage medications into a blister card format.



# Unit Dose / Reclaimable Packaging

**Blisters:** We offer a variety of blisters in standard clear and amber.

## Small

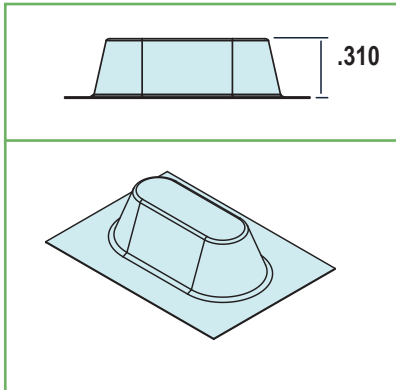

## Medium

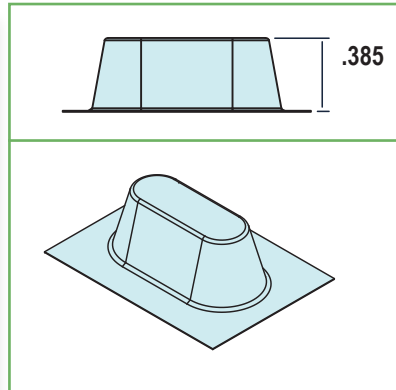

## Large

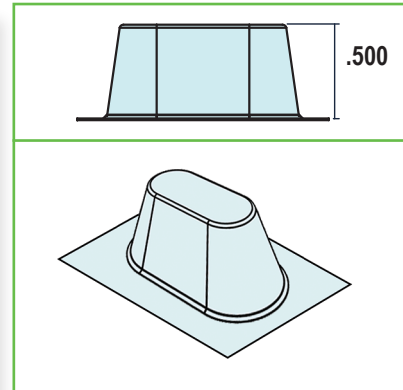

(Designed to nest together to optimize Box, Cart and Shelf space.)



## Extra Large

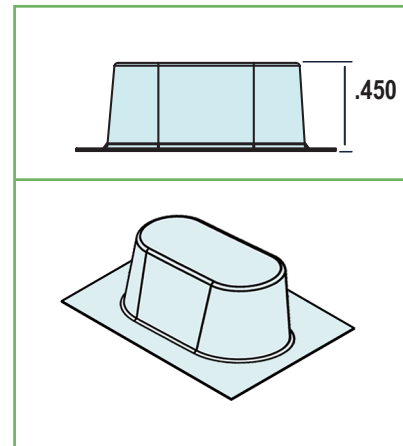

(Does not nest)



## Blisters, 1,000/Box

Item No.	Description
201-10	Small
201-11	Medium
201-13	Large
203-16	Large Amber
201-13XL	Extra Large (Does not nest)

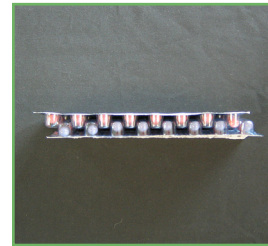

**Note:** Standard Unit Dose Blisters are produced 32 per sheet (4x8).  
Select blister sizes are available in 14, 28, 30 and 31 dose.

# Unit Dose / Reclaimable Packaging

## Reclaimable Packaging System

**Select Seal™ Cards:** Designed with a special select seal adhesive and a perforated card for the recovery of unused medications without damaging the blister or printed foil.

**Med Cards:** Provides a permanent seal (cannot be re-heated) to the unit dose foil and blister. Used when there are a number of individual doses that have been returned and require repackaging.

**Unit Dose Blisters:** Blisters are perforated and can be separated into strips or individual unit dose. They are designed to nest and can be stacked on top of one another for maximum storage capacity.

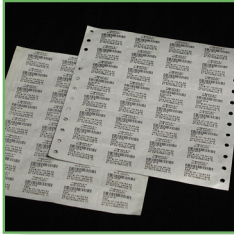

### Foil, 1,000/Roll

Item No.	Description
680-10	Dot Matrix Foil
680-11	Thermal Transfer Foil - Universal
680-19	Thermal Transfer Foil - One Step - Select Seal

Refer to Page 115

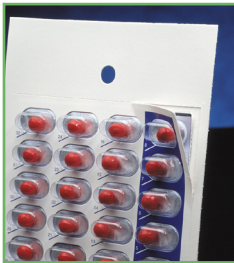

### Select Seal Cards, 500/Box

Item No.	Description
300-13	30-Day
300-14	31-Day
300-15	32-Day

Refer to Pages 47-49



### Non-Reclaimable Med Cards, 500/Box

Designed for re-packaging reclaimed medications.

Item No.	Description
300-73	30-Day Countdown
300-70	31-Day Countdown
300-72	32-Day Countdown
300-74	30-Day Countdown (Cold Seal)

Refer to Pages 49-51

### Cold Seal Non-Reclaimable Med Cards

Item No.	Description
300-74	30-Day Countdown (Cold Seal)



### Unit Dose Boxes, 1,000/Box

Item No.	Description
UD-250	(5" x 1 5/8" x 2 1/4")
UD-251	(4 11/16" x 1 9/16" x 2 3/8")

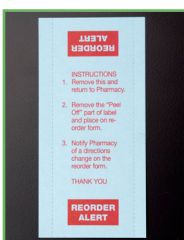

### Reorder Alert, 1,000/Box

Designed for use with Unit Dose boxes.

Item No.	Description
UD-286	Reorder Alert

## **MTS Unit Dose Foil Labeling System**

---

This unit dose foil labeling system meets the unique needs of the long-term care pharmacy by producing high quality bar code scannable label sheets quickly and efficiently. It is the only foil printing system developed specifically for pharmacy operations and produces up to 18 sheets per minute.

The Windows-based software is reliable and easy-to-use. Simply enter in the lot number and expiration date, then scan the medication NDC barcode. Additional data entry is also possible, including alternate drug names and customized fields. Changing to 1/2 tabs and 1/4 tabs, for example, is a simple process with “hot-key” field editing. The software also enables you to view the labels before you print.

The printable production report simplifies the process of tracking your pharmacy’s daily packaging activity.



### **The system includes:**

- Tharo H626 - 203dpi Thermal transfer printer
- H626 rotary cutter
- Labeling software program with database and report generator
- Barcode scanner with cable and stand
- Printhead cleaning kit
- Communication cable
- Initial set-up and training

### **Customer Furnished:**

Computer – Windows 7 or higher  
Standard printer for reports

### **Usage:**

This high-speed durable printer prints up to 18 sheets of Omnicell foil (576 unit doses) per minute. It is used for packaging efficiency or when barcode printing is required. It automatically cuts the foil to size, ready for direct application to the unit dose blister. The printer can be used as a standalone system or in conjunction with Omnicell automation.



# Growing with Single-Dose Packaging

## Printing Solutions

Software	69
Unit Dose Foil Labeling System	70
License Plate Labeling System	71
PillVue™ Color Labeling System	72
Label Applicators	73



### Labeling Software

Easy Label software interfaces with three types of printers to simplify the process of printing the following:

- Unit Dose Foil
- License Plate Labels
- PillVue Color Labels

This reliable and easy-to-use Windows-based software supports multiple styles of packaging used in long-term care pharmacy including unit dose, standard punch cards, and specialty items such as labels for syringes and controlled medications. The software's unique MVP (multi-view printing) feature allows simultaneous viewing and printing of up to three labels or foils to streamline the packaging process.

- FDA 21 CFR Part II compliant
- 2D barcode ready
- Windows XP & Windows 7 compatible 16 Digit, RSS/GS1 barcode and RFID capable
- Network and Terminal server versions available

### Software Options

**Single User** - Supports 3 printers per workstation\*.

**Terminal** - Supports multiple printers from multiple workstations among multiple locations.

**Network** - Supports multiple printers from multiple workstations within a single location.

\*When connected via USB, serial, or parallel port, the maximum distance between the computer and any one of the printers is 15 feet (does not apply to Ethernet communication.)





### Unit Dose Foil Labeling System

#### The System Includes

- Tharo H626 - 203dpi thermal transfer printer
- H626 rotary cutter
- Labeling software program with database and report generator
- Bar code scanner with cable and stand
- Printhead cleaning kit
- Communication cable
- Initial set-up and training

The unit dose foil labeling system meets the unique needs of the long-term care pharmacy by producing high quality bar code scannable label sheets quickly and efficiently. It is the only foil printing system developed specifically for pharmacy operations and produces up to 18 sheets per minute.

The Windows-based software is reliable and easy-to-use. You simply enter the lot number and expiration date and scan the medication's NDC barcode. Additional data entry is also possible, including alternate drug names and customized fields. Changing to 1/2 tabs and 1/4 tabs, for example, is a simple process with "hot-key" field editing. The software also enables you to view the labels before you print.

The printable production report simplifies the process of tracking your pharmacy's daily packaging activity.



See Page 114-116 For  
Foil & Ribbon Supplies



### License Plate Labeling System

#### The System Includes

- Tharo H435+ - 300dpi thermal transfer printer
- Labeling software program with database and report generator
- Bar code scanner with cable and stand
- Printhead cleaning kit
- Communication cable
- Initial set-up and training

This license plate labeling system is perfect for the long-term care pharmacy that requires bar code scannable labels in multiple label formats. This stand alone system features easy-to-use custom labeling software. Whether you need horizontal labels for standard punch cards, vertical labels for unit dose boxes, special labels for syringes, refrigeration, compounds, etc. - this system gives you the flexibility to create it all. Specialized design is simple, and you can even provide quick and positive identification of controlled medications by producing solid black labels with white text.

The thermal transfer printer can produce one label at a time for on-the-spot label application or produce an entire roll of labels for application at another work station.

You can also use this system to create your own bar codes to track previously non-bar coded inventory items, and print production reports to track your pharmacy's daily packaging activity.



See page 64 & 65 for  
License Plate Labels



### PillVue™ Color Labeling System

PillVue™ Color Labeling System captures high-resolution images of medications, which are used to produce full-color labels for faster, more accurate verifications. MVP (multi-view printing) software allows simultaneous viewing and printing of license plate labels, pill image labels, and foils to streamline the packing process.

#### The PillVue System Includes:

- Color label printer
- Starter ink and labels
- Camera system
- Barcode imaging scanner
- Starter drug database and images
- Communication cables
- Initial set-up and training



#### Printer Features:

- Print Speeds of up to 4.5" per second
- High-resolution color print images
- Fast dry semi-gloss photo labels
- Easy load 4 ink cartridge system
- MVP software and add-on printer capable

Computer and monitor NOT included.  
Foil printer additional.

#### Camera Features:

- High-resolution Camera
- Built in LED light source with polarizer
- Easy focus adjustments on camera
- Black-light lighting system system with polarizer
- Adjustable stand
- XY Base adjustment



Crystal clear images make verification more accurate and less time consuming.

# Printing Solutions

## Pre-pack Label Applicator

The Pre-pack Label Applicator automates the labeling process for your pre-pack operation and significantly reduces needed technician time.

Using a high-speed conveyor system, the Pre-Pack Label Applicator is used immediately after the packing process to automate the application of the pre-pack label. It prints, positions, and applies the label onto the pre-pack card, ensuring that medication, dosage, expiration, and other information is captured accurately and efficiently. Automating the pre-pack labeling process can significantly save technician time.

### Key benefits include:

- Ability to reallocate labor to higher-value tasks by eliminating manual printing and application of labels
- Ability to track individual technician productivity with the technician production report
- Ability to track inventory with the inventory production report

Date: 6\23\2016							
NDCNUMBER	QTY	DRUGNAME	STRENGTH	LOTNUMBER	TECH_INT	Scanned	ProductsPerMin
65862059805	14	TAMSULOSIN	0.4MG CAP	TMSA15447A	MA	98	1.075 ppm
68382023016	14	FENOFIBRATE	145MG TAB	1053074	MA	58	2.041 ppm
51991077290	14	LANSOPRAZOLE DR	30MG CAP	406086	MA	45	3.640 ppm
00536352141	28	MAGNESIUM OXIDE	400MG TAB	48154	MA	34	1.152 ppm
57896053101	28	MULTIVITAMIN W/MINERALS	TAB	531F01	MA	32	12.315 ppm
00904198860	60	MAPAP ES	500MG TAB(2T=1000MG)	47523	MA	30	0.727 ppm

Date: 6/23/2016				
Tech: MA				
14		FENOFIBRATE	145MG TAB	58
14		LANSOPRAZOLE DR	30MG CAP	45
14		TAMSULOSIN	0.4MG CAP	98
28		MAGNESIUM OXIDE	400MG TAB	34
28		MULTIVITAMIN W/MINERALS	TAB	32
60		MAPAP ES	500MG TAB(2T=1000MG)	30
<b>Total</b>				<b>297</b>



# Growing with SureMed by Omnicell Single Dose Packaging Solutions

## Expanding Through Automation

- Semi-Automated Fillers and Sealers
- Full-Automated Single Dose Automation



## The Next Step

- Handpacking with Heat Seal Single Dose Packaging



## Getting Started

- Handpacking with Cold Seal Single Dose Packaging





# Expanding Through Automation in Single Dose Packaging Packaging Equipment

## Fittings

---

Item # G-1022

T-Assembly



Item # G-1025

10 Ft. Hose Assembly



Item # G-1023

25 Ft. Hose Assembly



Item # G-1024

50 Ft. Hose Assembly



## Brushes (For MTS-350 and MTS-400 Packaging Equipment)

---

Item # 400-00

Stiff Brush



Item # 400-01

Soft Brush



Item # 400-05

Extra Soft Brush



\*Run brushes without meds for one hour and clean with 70% Isopropyl alcohol prior to the first use.

# Packaging Equipment

## Semi-Automated Fillers & Sealers

### MTS-350™

Combining semi-automated filling and sealing processes, our MTS-350 provides a versatile pre-pack solution for the long-term care pharmacy.

#### Benefits

- Packages up to 10 times faster than packaging by hand
- Designed for less repetitive operator motion
- Robust automated sealing station eliminates blister card pressure variants
- Temperature and time controls provide consistent quality sealing

#### Features

- Packages a wide variety of card styles and foils to meet a variety of needs
- Motorized medication filling system with adjustable speed and easy to change brushes
- Tool-less changeover of the filling system
- Seal station automatically opens when the cycle is complete
- Easy-to-read digital temperature controller
- Stainless steel and anodized aluminum construction allow for easy cleaning
- Easy access for cleaning of heat plate
- Dual timer for unit dose and blister card sealing

#### Recommended Accessories

- 10-50 Ft. Hoses #G-1025, G-1023, G-1024
- T-Assembly #G-1022
- Stiff Brush #400-00
- Soft Brush #400-01
- Extra Soft Brush #400-05



#### Specifications

- **Height:** 33" (over filler)
- **Width:** 37-7/8"
- **Depth:** 28"
- **Weight:** 112 lbs
- **Electrical:** 110 VAC, 7Amps
- **Compressed Air:** 100 PSI, 2SCFM
- **Sealing Time:** Adjustable: Standard Blister Card / 4 seconds, Unit Dose / 2 seconds
- **Temperature Range:** 90° - 400° Fahrenheit
- **Service Contracts:** Annual service contracts are available

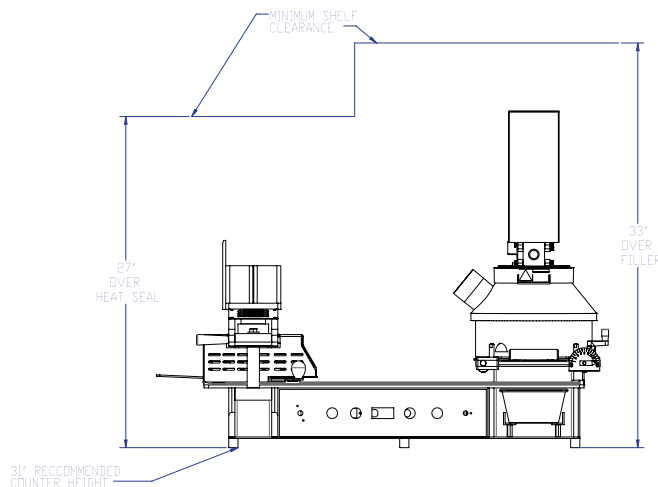
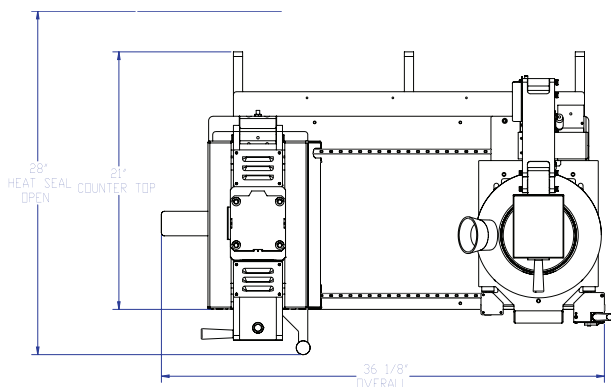



# Packaging Equipment

## Semi-Automated Fillers & Sealers

### MTS-500™

Designed to streamline packaging for the larger long-term care pharmacy, our MTS-500 is capable of producing approximately 850<sup>1</sup> completed medication blister cards per hour.

#### Benefits

- Packages up to 34 times faster than packaging by hand
- High-volume throughput with a semi-automated system
- Temperature and time controls provide consistent quality sealing
- Robust automated sealing station eliminates blister card pressure variants
- Optimal sealing at minimum heat levels
- All settings are pre-programmed

#### Features

- Motorized medication filling system with adjustable speed and easy-to-change brushes
- Tool-less changeover of the filling system
- Easy-to-read digital temperature controller
- Stainless steel and anodized aluminum construction allows for easy cleaning
- Optional in-line printing system for pre-pack labeling and bar coding

#### Specifications

- **Height:** 66"
- **Width:** 74-1/4" with printer
- **Depth:** 86-1/4" with printer
- **Weight:** 1200 lbs
- **Electrical:** 240 VAC, 1Phase, 20 Amps
- **Compressed Air:** 100 PSI, 15 SCFM
- **Temperature Range:** 90° - 400° Fahrenheit

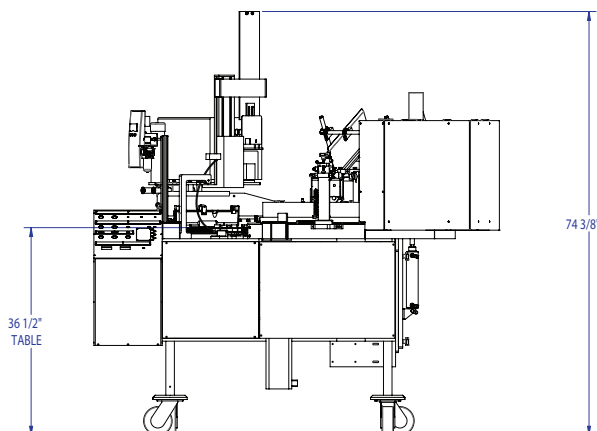

#### Recommended Accessories

- 10-50 Ft. Hoses #G-1025, G-1023, G-1024
- T-Assembly #G-1022
- Stiff Brush #400-00
- Soft Brush #400-01

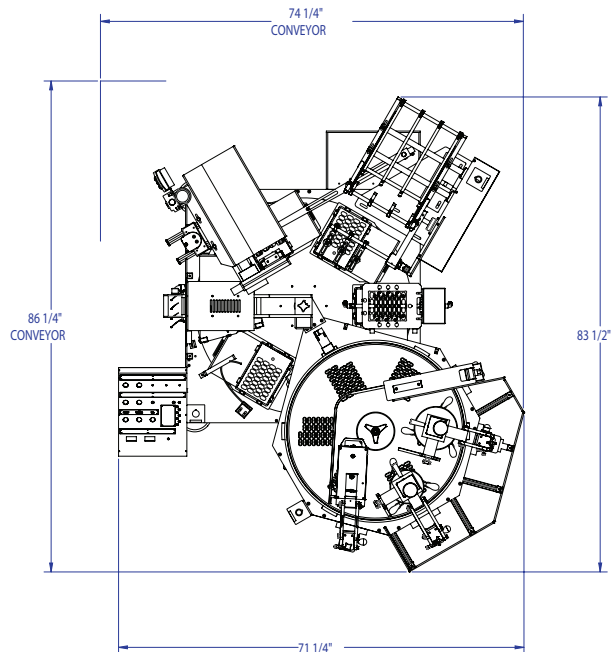

ALLOW ADDITIONAL 2' WALKAROUND EACH SIDE.

<sup>1</sup> Max per hour is one technician filling the same drug without medication changes.



### Deblistering Machine

Save time and money on medication removals using our easy-to-use deblistering machine.

#### Benefits

- Reclaims medications for disposal
- Saves time and money

#### Features

- Small and portable
- Hand operated
- Removes medication easily from punch cards
- Heavy duty design

#### Specifications

- **Height:** 12"
- **Width:** 9.25"
- **Depth:** 16"
- **Weight:** 25 lbs
- **Material:** Stainless steel and anodized aluminum

Available for Omnicell Standard and Omnicell DOSIS cards.

Custom dies are also possible. **Call us for a quote 800-671-0589.**

Tote not included



### Label Conveyor Applicator

The LCA System enables you to capitalize on the efficiencies of the MTS-350 and MTS-400 with the addition of a high-speed label application system to significantly increase the speed of the labeling process.

Refer to page 68 to find out more about the LCA System.

# Expanding Through Automation with Single-Dose Packaging Omniceil AccuFlex®

## Omniceil Accuflex

Flexible, patient specific, automated packaging for the long-term care (LTC) pharmacy. The AccuFlex® combines proven Omnicell OnDemand technology with Fanuc Robotics to create accurate and efficient automation with the flexibility to fill a variety of medication packaging on demand.

Omniceil OnDemand® automation interfaces with your existing pharmacy information system to enhance scheduling and workflow management and improve accuracy and production of medication packaging. Omnicell AccuFlex® allows a pharmacy to fill cards as soon as medication orders are received, rather than pre-packing medications in anticipation of future orders, leading to decreased inventory costs and increased pharmacy cash flow.



## Benefits

- Improved operational efficiency and inventory management
- Scalable cassette selection, custom-fitted to your operation
- Efficiently package different medication systems with a single piece of automation
- Low maintenance, reliable components and proven technology
- Patented design optimizes output and accuracy
- Intuitive software that is flexible enough to accommodate your operational environment

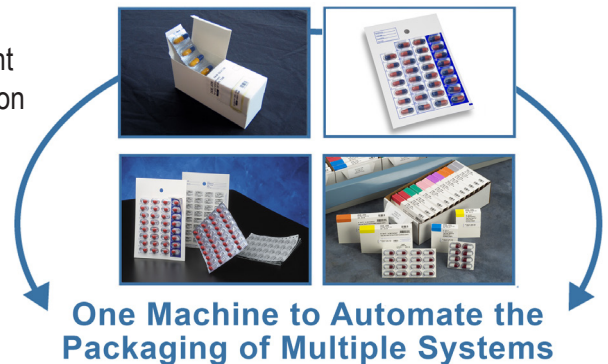

## Features

- Provides on-demand order fulfillment for different dispensing cycles and partial fills
- Accessibility to an unlimited number of cassettes depending on individual pharmacy needs
- Quick changeover from one type of packaging to another
- Integrated robotics, proven OnDemand technology and high-speed linear motors
- Interfaces with most commercial pharmacy information systems
- Flexible order processing to accommodate sorting by batch, time, facility or patient
- Pneumatic sealing and automated prescription label applicator

Discover how automation can help decrease medication inventory costs and increase pharmacy cash flow.  
**Call one of our sales consultants at 800-671-0589.**

# Expanding Through Automation with Single-Dose Packaging Omniceil Express II™

The Express II fills patient-specific punch cards creating a made-to-order solution for pharmacy customers.

The Express II is high-speed pharmacy automation that is designed to:

- Maximize workflow
- Improve pharmacy productivity
- Increase profitability

The Express II system includes: high-speed packaging technology, software, reports, formulary management, inventory management, cards, blisters, labels, labeling system, installation, training and support.

## Benefits

- Verification system ensures all cassettes are managed by the system and maintains medication inventory
- Allows just-in-time ordering of medications to help increase inventory cost savings
- Ability to grow your pharmacy business without adding additional personnel

## Features

- Highly accurate at a speed of 10 cards per minute
- Patient-specific card filling
- Fully automates the process from medication selection to the finished product
- Fully interfaces with the Pharmacy Information System
- Automated bar code verification and tracking
- Generates detailed and custom reports



Find out how OnDemand Express II can measurably increase a pharmacy's throughput. **Call 800-671-0589.**

## DOSIS 31-Day Card, 500/Box

Item No.: 300-50-B310V

Description: 31 Front One-Piece/  
Large Oval Blister Card

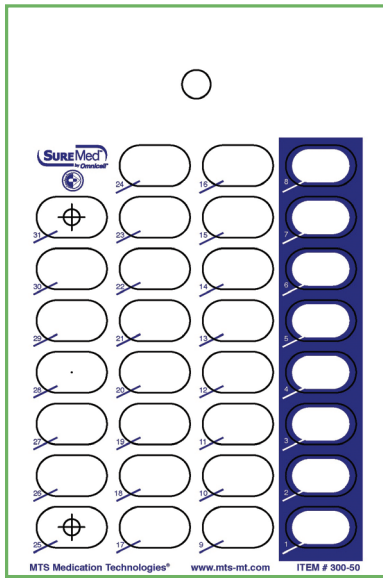

Also available with medium blisters.

## DOSIS 31-Day Calendar Card, 500/Box

Item No.: 300-51-B31#10V

Description: 31 (#1) Front One-Piece/Large  
Oval Blister Card

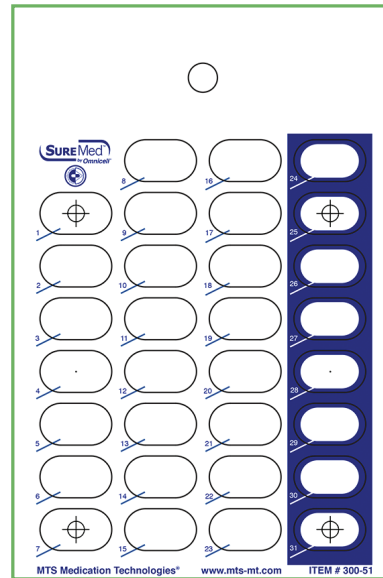

## DOSIS 31-Day Lidding, 1,000/Box

Item No.: L-300-50

Description: Lidding for back of #300-50-B310V

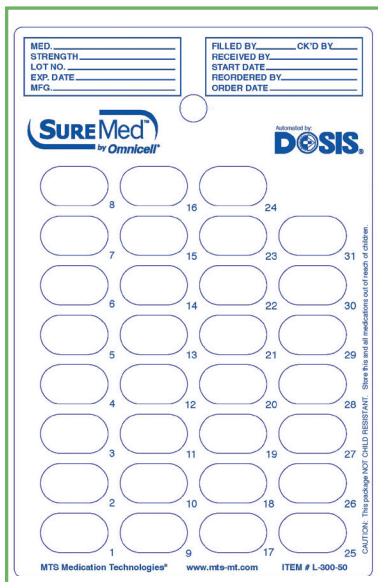

## DOSIS 31-Day Calendar Card Lidding, 1,000/Box

Item No.: L-300-51

Description: Lidding for back of #300-51-B31#10V

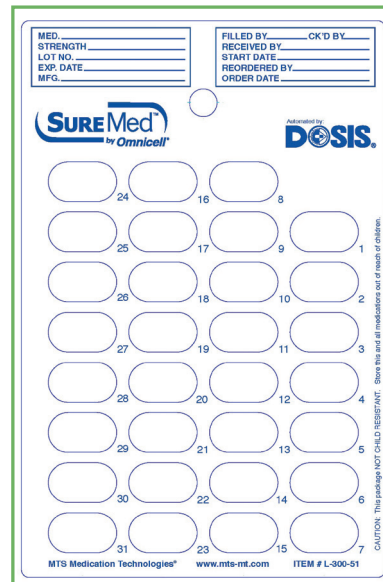



## DOSIS 30-Dose Card, 500/Box

Item No.: 300-30-B30OV

Description: 30-Front One-Piece/Large Oval Blister Card

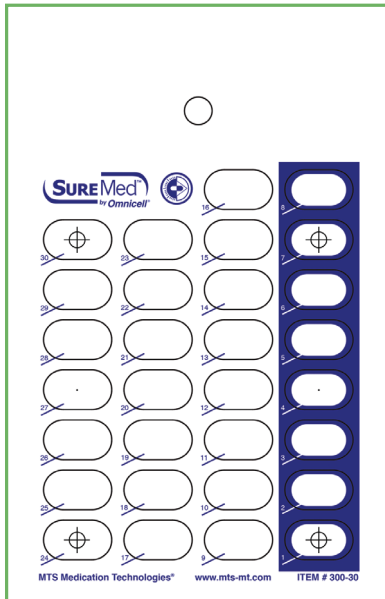

## DOSIS 30-Dose Lidding, 1000/Box

Item No.: L-300-30

Description: Lidding for back of #300-30-B30OV

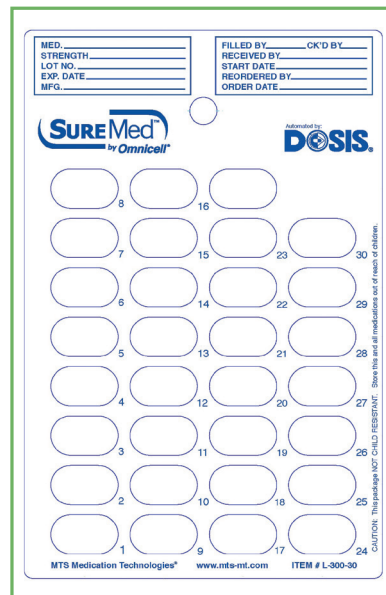

# Labels for DOSIS Automation

## Specialty Labels: DOSIS

### Item # L-300-52

Size: 4" X 2" With Reorder Tab

Paper: Direct Thermal (No Perf Between Labels)

Finish: 1.5" cores, Rolled Inward, 4M/Box



### Item # L-300-53

Size: 4" X 2" With Reorder Tab

Paper: Direct Thermal (Perf Between Labels)

Finish: 1.5" cores, Rolled Inward, 4M/Box



### Item # L-300-54

Size: 4" X 2" NO REORDER TAB

Paper: Direct Thermal (No Perf Between Labels)

Finish: 1.5" cores, Rolled Inward, 4M/Box



### Item # L-300-55

Size: 4" X 2" NO REORDER TAB

Paper: Direct Thermal (Perf Between Labels)

Finish: 1.5" cores, Rolled Inward, 4M/Box



### Item # L-300-56

Size: 4" X 2" Four Color "Time Pass" DOSIS machine label with Reorder Tab

Paper: Direct Thermal (No Perf Between Labels)

Finish: 1.5" cores, Rolled Inward, 4M/Box



### Item # L-300-57

Size: 4" X 2" Four Color "Time Pass" DOSIS Hand Applied label with Reorder Tab

Paper: Direct Thermal (Perf Between Labels)

Finish: 1.5" cores, Rolled Inward, 4M/Box

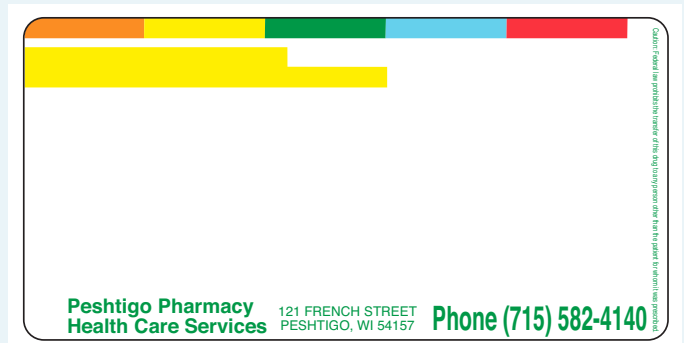

Did you know that Omnicell can manufacture custom DOSIS labels? **Contact us at (800) 671-8439 for a quote.**



# Medication Cabinets

## Improve Medication Access and Operational Efficiency

Long-term care providers are increasingly seeking the benefits of automated medication and supply systems for their sites. Such systems aid in regulatory compliance and security, and help increase quality of care for residents by enabling faster access to first doses, new medication orders, and emergency medications.

Omnice<sup>®</sup> automated medication and supply cabinet systems enable timely access to needed medications at the point of care. Instead of managing multiple e-kits, authorized caregivers can access most medications from the Omnicell automated medication cabinet, which easily stores 200 to 300 different items or more depending on the configuration. This system reduces stat deliveries and back-up pharmacy costs by enabling first doses, new orders, and emergency medications to be issued from the Omnicell automated cabinet.



# Medication Cabinets

## Omnicell® Medication and Supply Automation Systems

### Benefits

**Reduced Costs** – Eliminate time consuming e-kits and reduce the need for stat deliveries for fulfilling first doses, new orders, and emergency medications.

**Improved Charge Capture** – Labor-intensive manual billing is replaced with an accurate, automated process, including the ability to charge by NDC as an item is removed.

**Promotes Clinical Quality** – Patients will have faster access to medications. The LTC facility can more effectively handle changes in patient flow and drug regimens for higher-acuity patients.

**Compliance** – The system makes it easier to manage and monitor chain of custody and medication use, and helps meet Joint Commission and other regulatory requirements.

### Why Choose Omnicell for Long-Term Care?

Omnicell offers a tailored system for long-term care pharmacy infrastructure and a collaborative implementation model that minimizes installation time.

- A single server supports a secure plug-and-play Internet connection at each long-term care site.
- No hassle of modems and VPN connections.
- Hosted server option available.
- ADT, billing, and profile interfaces provide advanced functionality.

### Omnicell System Features

**Guiding Lights Technology** – Quickly directs the user to the desired location in the cabinet.

**Anywhere RN™ Remote Medication Management Software** – Allows caregivers to queue up medications remotely, saving time and energy.

**Integrated Medication Label Printer** – Print patient-specific labels right from the cabinet to prevent mix-ups and meet Joint Commission requirements.

**Touch & Go™ G4 Biometric ID System** – Fast, secure access to the cabinet via fingerprint scan.

**OmniExplorer** – View inventory in all Omnicell cabinets to adjust stock and get emergency supplies.

### Omnicell System Feature

Omnicell cabinets come in a variety of sizes and formats. They can be custom configured with different drawer types in varying degrees of security. A few examples are shown here.



**Locking Lid Drawer**  
A high security option



**Lighted Matrix Drawer**  
Adjustable bin dividers  
offer flexibility



**Medication/Supply Drawer**  
Includes easy-to-use reorder buttons

# Labels & Printing Supplies

## Labels & Printing Supplies

Custom Labels	87
Stock Labels	88
Speciality Labels	95
Software Specific Labels	97
Ribbons	114
Foil	115

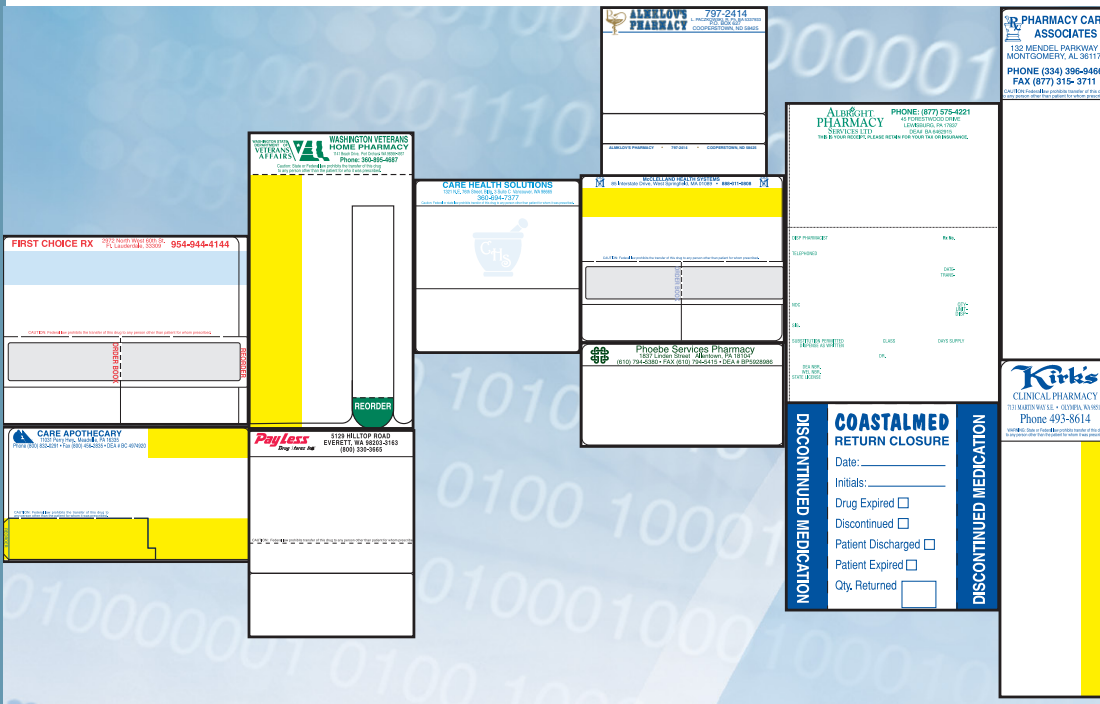

No matter your requirements, Omnicell has the right labels for you.

### Custom Labels

Omnicell has specialized in customized pharmacy labels for the last 20+ years. With 2 separate production facilities, we continue to supply a high-quality product with consistent on-time delivery. Our in-house graphics department will help you customize your label design to make it uniquely your own. Choose from a wide array of dies or have a die designed for your own specific needs. The minimum quantity for a custom order is 25,000. Call us today to discuss your new or existing custom needs. When it comes to your pharmacy labels, our experts can make it simple.

Send a sample of your own label today and we will provide you with a quote. Why pay more than you need to when you can buy directly from the manufacturer?



\*Offer valid for new label customers only. Offer not available on Laser labels or RFID labels. Not valid with any other offer.

### Cover Up Labels Now Available!

**Tired of Scraping Off Old Script Labels on Returns?** What a waste of time, effort and money. Omnicell now offers cover up or blackout labels. Simply cover up the old label with one of these blank white labels and place another RX script label on top of it. Our specially designed cover up labels have a special adhesive with black ink added so it blacks out any wording or information below the label and allows you a clean slate to place your new label on. These custom labels are made to order and can be made to fit over any label you use.

**Call our label specialist today for a quote 1-800-671-8439.**

### Prescription Labels

Item # L-021-D  
Rx Label

Size: 3" x 2 23/32"  
Paper: Pin Fed - Single Ply  
Finish: Fanfold / 5M/Box

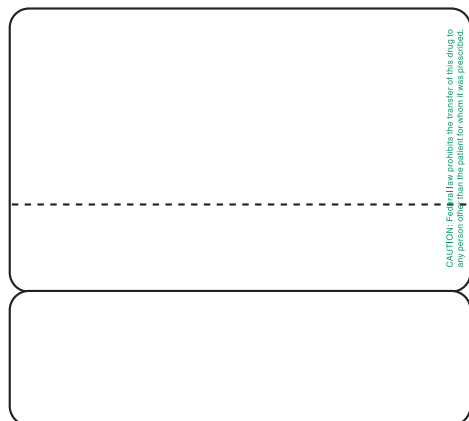

Item # L-021-A  
Rx Label

Size: 3" x 2 3/4"  
Paper: Pin Fed - Single Ply  
Finish: Fanfold / 5M/Box

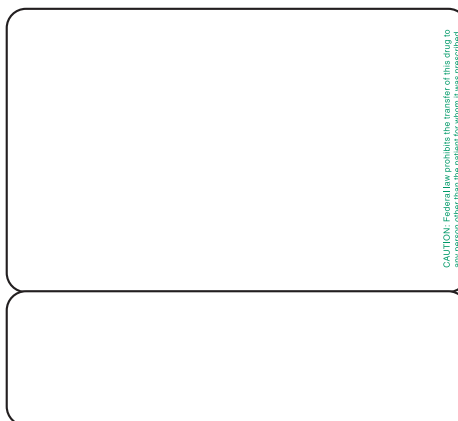

### Ancillary & Time Pass Labels

---

Item # L-005A

Finish: Roll

Qty: 1M

**AM AM AM**

Item # L-005AA

Finish: Roll

Qty: 1M

**MIDNIGHT**

Item # L-005AB

Finish: Roll

Qty: 1M

**ALL SHIFTS**

Item # L-005AC

Finish: Roll

Qty: 1M

**6:AM**

Item # L-005AG

Finish: Roll

Qty: 1M

**SPECIAL**

Item # L-005AK

Finish: Roll

Qty: 1M

Rx# \_\_\_\_\_  
PATIENT NAME \_\_\_\_\_  
SEE OUTSIDE CONTAINER FOR DIRECTIONS

Item # L-005AL

Finish: Roll

Qty: 1M

DATE SEAL  
BROKEN \_\_\_\_\_

Item # L-005AO

Finish: Roll

Qty: 3M

**START HERE**

Item # L-005AQ

Finish: Roll

Qty: 1M

**AS NEEDED**

Item # L-005AR

Finish: Roll

Qty: 1M

**Medication Discontinued**  
Date \_\_\_\_\_ Qty \_\_\_\_\_

Item # L-005AT

Finish: Roll

Qty: 1M

**MIDDAY**

Item # L-005G

Finish: Roll

Qty: 1M

**AM HS**

# Labels & Printing Supplies

## Stock Labels

### Ancillary & Time Pass Labels

---

Item # L-005H

Finish: Roll

Qty: 1M



Item # L-005I

Finish: Roll

Qty: 1M



Item # L-005J

Finish: Roll

Qty: 1M



Item # L-005K

Finish: Roll

Qty: 1M



Item # L-005L

Finish: Roll

Qty: 1M



Item # L-005M

Finish: Roll

Qty: 1M



Item # L-005N

Finish: Roll

Qty: 1M



Item # L-005AU

Finish: Roll

Qty: 1M



Item # L-005B

Finish: Roll

Qty: 1M



Item # L-005C

Finish: Roll

Qty: 1M



Item # L-005D

Finish: Roll

Qty: 1M



Item # L-005E

Finish: Roll

Qty: 1M



Item # L-005F

Finish: Roll

Qty: 1M



### Ancillary & Time Pass Labels

---

Item # L-005O

Finish: Roll

Qty: 1M

**BALANCE OF ORDER**

Item # L-005P

Finish: Roll

Qty: 1M

**BALANCE TO FOLLOW**

Item # L-005Q

Finish: Roll

Qty: 1M

**HOUSE SUPPLY**

Item # L-005R

Finish: Roll

Qty: 1M

**DIRECTION  
CHANGE  
SEE CHART**

Item # L-005S

Finish: Roll

Qty: 1M

**MORNING**

Item # L-005T

Finish: Roll

Qty: 1M

**AFTERNOON**

Item # L-005U

Finish: Roll

Qty: 1M

**EVENING**

Item # L-005V

Finish: Roll

Qty: 1M

**BEDTIME**

Item # L-005W

Finish: Roll

Qty: 1M

**MEDICATION EXPIRES ONE  
YEAR FROM DATE OF FILLING**

Item # L-005Y

Finish: Roll

Qty: 1M

**CANNOT BE REFILLED  
UNTIL \_\_\_\_\_**

Item # L-005Z

Finish: Roll

Qty: 1M

**BUBBLE CONTAINS  
1/2 TABLET**

Item # L-005SM

Finish: Roll

Qty: 1M

**STOP  
MED.**

Item # L-005AV

Finish: Roll

Qty: 1M

**Call your doctor for medical  
advice about side effects.  
You may report side effects  
to FDA at 1-800-FDA-1088.**

Item # L-005CA

Finish: Roll

Qty: 1M

**Med. Discontinued on:  
Date \_\_\_/\_\_\_/\_\_\_ Init. \_\_\_**



**Psychotropic Labels**

---

Item # L-031A

**BOXED WARNING MEDICATIONS**  
This medication has a **Boxed Warning**, the strongest warning mandated by the FDA, which indicates a need to closely evaluate and monitor the potential benefits and risks of the medication.

Item # L-031B

**Anti-anxiety**  
Observe the patient closely for significant side effects.  
**SIDE EFFECTS:** - Sedation, Drowsiness, Ataxia (drunk walk), Dizziness, Nausea, Vomiting, Confusion, Headache, Blurred Vision, Skin Rash.  
**SPECIAL ATTENTION:** If given with other sedatives or hypnotics, alcohol.

Item # L-031C

**Antipsychotic**  
Observe the patient closely for adverse reactions.  
**COMMON SIDE EFFECTS:** sedation, weight gain, dry mouth, constipation, increased salivation, urinary incontinence/retention, anxiety, gynecomastia  
**SERIOUS SIDE EFFECTS:** movement disorders (EPS), severe hypotension, tardive dyskinesia, diabetes, seizures, priapism, QT prolongation, blood dyscrasias, NMS  
**BLACK BOX:** increased risk of death in elderly dementia patients.

Item # L-031D

**Sedative/Hypnotics**  
Observe the patient closely for significant side effects.  
**SIDE EFFECTS:** Common - Sedation, Drowsiness, Morning Hangover, Ataxia (drunk walk).  
**SPECIAL ATTENTION:** If given with other sedatives or hypnotics and alcohol.

Item # L-031E

**Selective Serotonin Reuptake Inhibitors**  
**Common Side Effects:** Nausea, nervousness, agitation or restlessness, drowsiness, insomnia, dizziness, weight fluctuations, headache, dry mouth, vomiting and or diarrhea  
**Serious Side Effects:** Serotonin Syndrome  
**BLACK BOX WARNING:** Patients of all ages who are started on antidepressant therapy should be monitored appropriately and observed closely for clinical worsening, suicidality, or unusual changes in behavior.

Item # L-031F

**Atypical Antipsychotics**  
Increased mortality in the elderly patients with dementia-related psychosis (approx. 1.5 times greater than placebo) makes these drugs unapproved for treatment of dementia-related psychosis in the elderly. Frequent (greater than 2%) adverse reactions include agitation, akathisia, constipation, dizziness or drowsiness, EPS, hyper/hypotension, insomnia, nausea, tachycardia and weight gain (adapted from Facts & Comparisons).

Item # L-031G

**Look Alike/  
Sound Alike Drug**  
**CAUTION:** This drug has one or more look alike/sound alike drugs which may be confused for this drug. Verify this drug to the original order.

Item # L-031H

**Anti-Depressant**  
Observe the patient closely for significant side effects.  
**SIDE EFFECTS:** - Common - Sedation, Drowsiness, Dry Mouth, Blurred Vision, Urinary Retention, Tachycardia, Muscle Tremor, Agitation, Headache, Skin Rash, Photosensitivity (skin). Excess Weight Gain.  
**SPECIAL ATTENTION FOR:** Heart Disease, Glaucoma, Chronic Constipation, Seizure Disorder, Edema.

Each is rolled 1,000 per roll. Sold by roll. Color may vary slightly.

**Prescription Labels**

---

Item # L-506-B2  
Rx Label

Size: 3 11/16" x 2 3/4"  
Paper: Thermal Transfer  
Finish: Roll 3" Core / 4M/Box

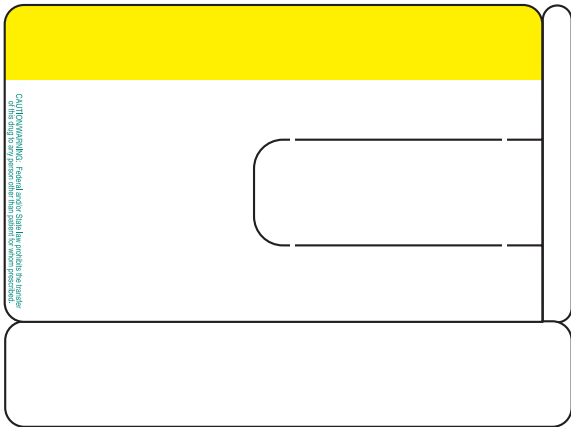

Item # L-506-C2  
Rx Label

Size: 3 1/2" x 5 1/16"  
Paper: Direct Thermal  
Finish: 1 1/2" Core / 3.5M/Box

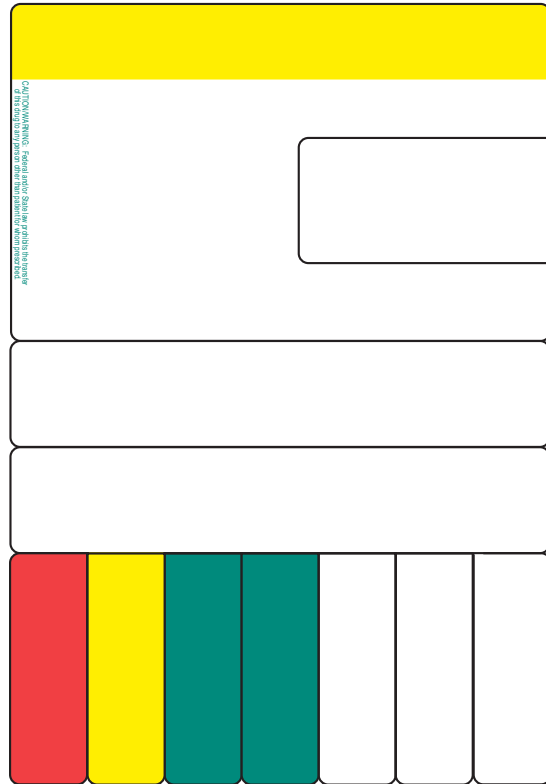

### Pre-Pack Labels

---

Item # L-019-B  
Thermal Transfer -  
Auto Apply Compatible

Size: 2 3/4" x 1 15/16"

Paper: Thermal Transfer

Finish: Roll 3" Core / 30M/Box



Item # L-019-C  
Thermal Transfer -  
Auto Apply Compatible

Size: 1 7/8" x 1 3/8"

Paper: Thermal Transfer

Finish: Roll 3" Core / 54M/Box



Recommended Accessories:

TTR Ribbon #TTR-008

Item # L-019-D  
Thermal Transfer -  
Auto Apply Compatible

Size: 3" x 2"

Paper: Thermal Transfer

Finish: Roll 3" Core / 23.2M/Box



Item # L-019-E  
Thermal Transfer -  
Auto Apply Compatible

Size: 2 1/2" x 1 1/2"

Paper: Thermal Transfer

Finish: Roll 3" Core / 28.8M/Box



### Pre-Pack Labels

---

Item # L-019-EY  
Yellow & White - Thermal  
Transfer Auto Apply Compatible

Size: 2 1/2" x 1 1/2"

Paper: Thermal Transfer

Finish: Roll 3" Core / 32M/Box

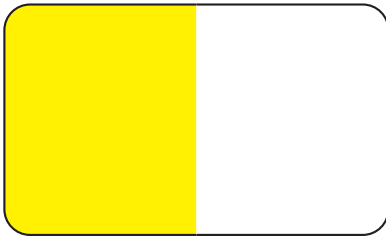

Item # L-019-F  
Thermal Transfer - Auto  
Apply Compatible

Size: 1 1/2" x 1"

Paper: Thermal Transfer

Finish: Roll 3" Core / 88M/Box



Item # L-503-D1  
Direct Thermal

Size: 1 3/4" x 1 1/4"

Paper: Direct Thermal

Finish: Roll 3" Core / 20M/Box

Finish: Also available in Pink, Yellow and Lt. Blue



Item #L-510-D1  
Direct Thermal

Size: 4" x 1 7/8"

Paper: Direct Thermal

Finish: Roll 5" Core / 12M/Box



ITEM# L-510-D2  
Direct Thermal

Size: 4" X 2 1/8"

Paper: Direct Thermal

Roll: 5" Core, 12M/Box

### Specialty Labels: Unit Dose

---

#### Item # L-017-C Return Closure-Unit Dose Box

Size: 3" x 2 15/16"

Paper: Single Ply/EDP / Rem. Adh.

Finish: Sheeted/2 Across / 5M/Box

DISCONTINUED MEDICATION	<b>RETURN CLOSURE</b>	DISCONTINUED MEDICATION
	Date: _____	
	Initials: _____	
	Drug Expired <input type="checkbox"/>	
	Discontinued <input type="checkbox"/>	
	Patient Discharged <input type="checkbox"/>	
	Patient Expired <input type="checkbox"/>	
Qty. Returned <input type="checkbox"/>		

### Specialty Labels: OnDemand®

---

#### Item # L-026 Rx Label-Auto

Size: 4" x 8"

Paper: Direct Thermal

Finish: Roll 5" Core / 3M/Box

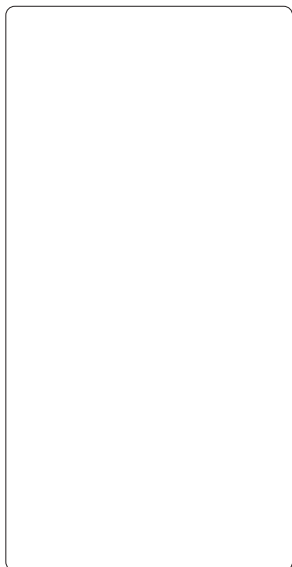

#### Item # L-202 SureMed Thermal Label

Size: 4" x 8.75"

Paper: Thermal

Finish: Roll 5" Core / 1M/Box

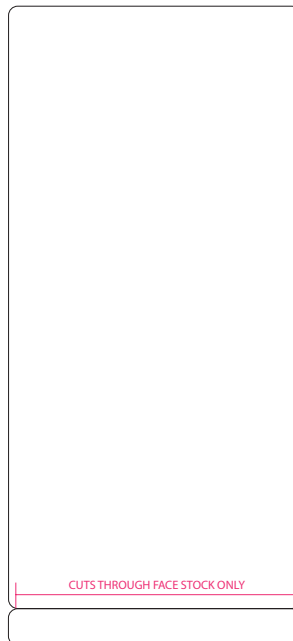

### IV Labels

#### Item # L-021-B IV Compressed

Size: 2 1/2" x 3 5/16"  
Paper: Pin Fed /  
Single Ply Finish:  
Fanfold / 5M/Box

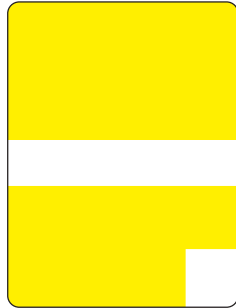

#### Item # L-021-C IV with Syringe Labels

Size: 4 13/32" x 3 3/8"  
Paper: Pin Fed /  
Single Ply Finish:  
Fanfold / 5M/Box

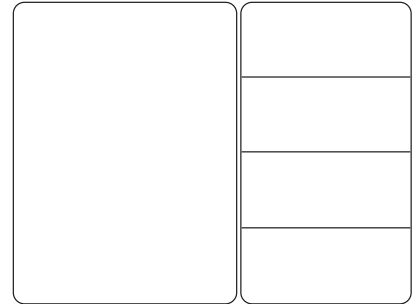

### Specialty Labels: SureMed Day-of-Week Med Sync Spine Labels

#### Item # L-205

Size: 0.75" x 9.5"  
For use with: 301-31, 301-37, 301-33, 4M/Box

TUES	TUES	TUES	TUES
WED	WED	WED	WED
THURS	THURS	THURS	THURS
FRI	FRI	FRI	FRI
SAT	SAT	SAT	SAT
SUN	SUN	SUN	SUN
MON	MON	MON	MON

L-205-A	Monday – Sunday
L-205-B	Tuesday – Monday
L-205-C	Wednesday – Tuesday
L-205-D	Thursday – Wednesday
L-205-E	Friday – Thursday
L-205-F	Saturday – Friday
L-205-G	Sunday - Saturday

#### Item # L-204

Size: 1" x 8.5"  
For use with: 301-35, 4M/Box

SUN	SUN	SUN	SUN
MON	MON	MON	MON
TUES	TUES	TUES	TUES
WED	WED	WED	WED
THURS	THURS	THURS	THURS
FRI	FRI	FRI	FRI
SAT	SAT	SAT	SAT

L-204-A	Monday – Sunday
L-204-B	Tuesday – Monday
L-204-C	Wednesday – Tuesday
L-204-D	Thursday – Wednesday
L-204-E	Friday – Thursday
L-204-F	Saturday – Friday
L-204-G	Sunday - Saturday

# Labels & Printing Supplies

## Specialty Labels

### Specialty Labels: Opti-Pak™

#### Item # L-301-B1 thru L-301-B8 Opti-Pak - Color Coded Rx Labels

Size: 1 1/2" x 1"  
Paper: Single Ply  
Finish: Fanfold / 5M/Box

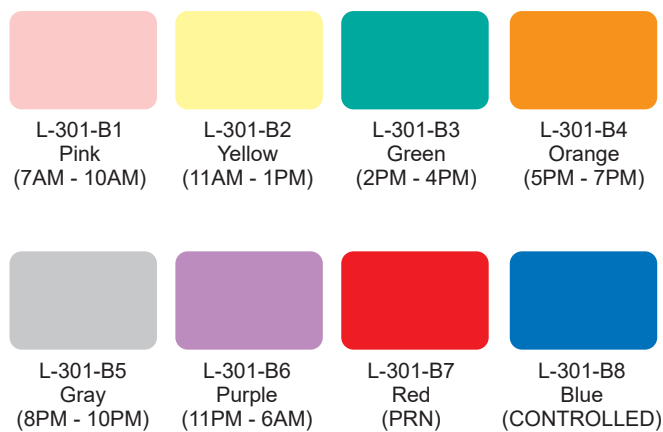

#### Item # L-301-KIT Opti-Pak - Time Pass Kit All Colors

Size: 1 1/2" x 1"  
Paper: Single Ply  
Finish: Fanfold / 1,000/Color=8,000/Box



### Specialty Labels: Mealtime - Make Any Card a Mealtime Card!

#### Item # L-025-A Mealtime Label

Size: 3 1/2" x 1 1/4"  
Paper: Single Ply  
Finish: Fanfold / 5M/Box

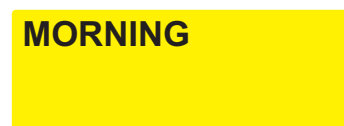

#### Item # L-025-B Mealtime Label

Size: 3 1/2" x 1 1/4"  
Paper: Single Ply  
Finish: Fanfold / 5M/Box

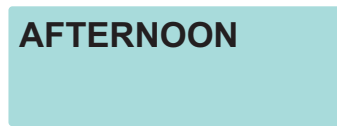

#### Item # L-025-C Mealtime Label

Size: 3 1/2" x 1 1/4"  
Paper: Single Ply  
Finish: Fanfold / 5M/Box

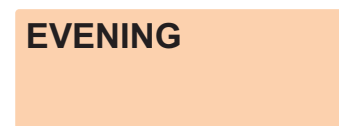

#### Item # L-025-D Mealtime Label

Size: 3 1/2" x 1 1/4"  
Paper: Single Ply  
Finish: Fanfold / 5M/Box



#### Item # L-025-E Mealtime Label

Size: 3 1/2" x 1 1/4"  
Paper: Single Ply  
Finish: Fanfold / 5M/Box





# Labels & Printing Supplies

## Software Specific Labels

**Software Specific Labels:** Below are the major pharmacy software systems used in the LTC pharmacy market. For each software vendor we have associated custom dies and label orders that have been run recently. When deciding on or creating a new label design, use the illustrated drawings as a starting point. Both the die and the software compatibility already exist.

### HBS (Health Business Systems) Software Labels

#### Die # 518T

Size: 3 5/8" x 3"  
Paper: Thermal

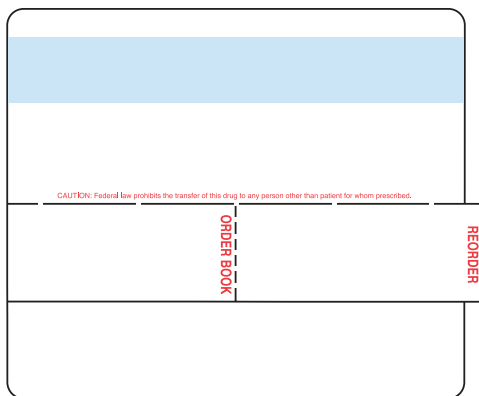

#### Die # 152/551

Size: 2 3/4" x 3 13/32"  
Paper: Single Ply/Thermal

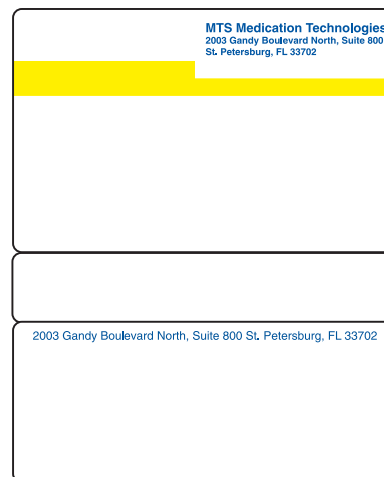

#### Die # 424T

Size: 3 11/16" x 3 5/8"  
Paper: Single Ply / Thermal

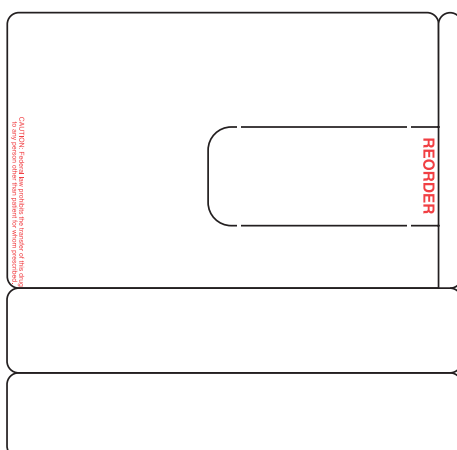

#### Die # 393

Size: 3 3/4" x 4 1/4"  
Paper: Thermal

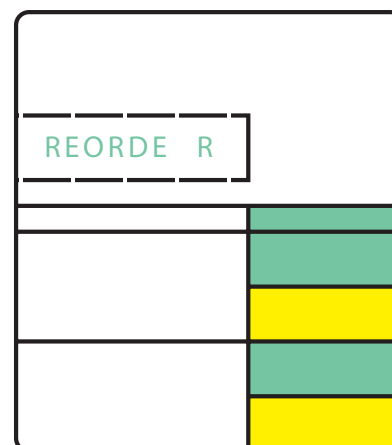

### HBS (Health Business Systems) Software Labels

#### Die # 420

Size: 4 3/32" x 2 1/2"

Paper: Single Ply / Thermal

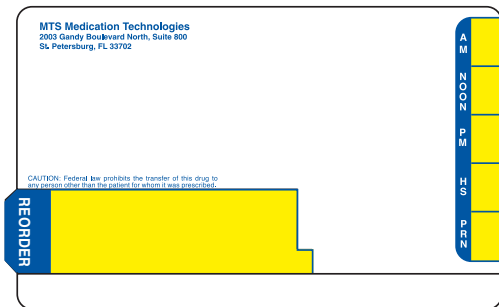

#### Die # 524

Size: 4 3/16" x 3 1/8"

Paper: Thermal

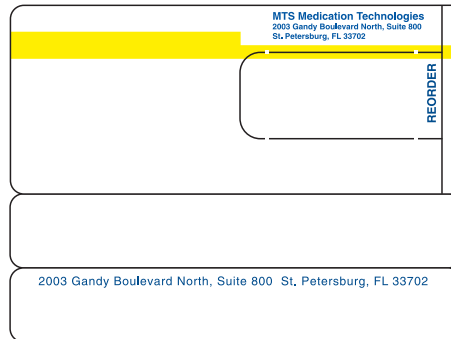

#### Die # 350T

Size: 3 11/16" x 2 3/4"

Paper: Single Ply / Thermal

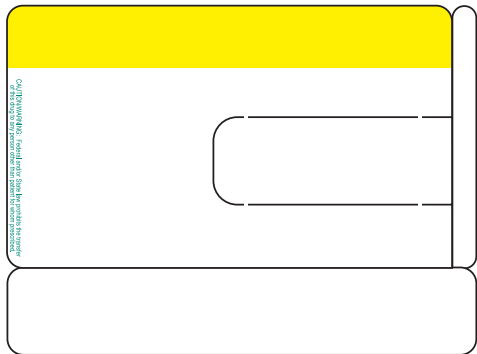

#### Die # 612

Size: 3 5/8" x 2 1/4"

Paper: Single Ply / Thermal

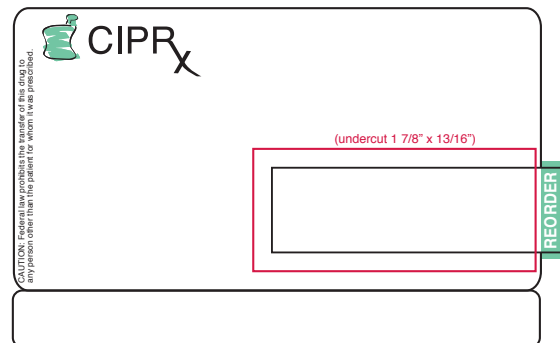

#### Die # 453

Size: 4" x 1 27/32"

Paper: Thermal

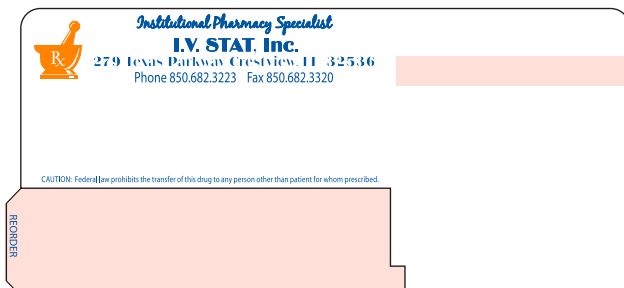

# Labels & Printing Supplies

## Software Specific Labels

### McKesson Pharmacy Systems

Die # 350T

Size: 3 11/16" x 2 3/4"

Paper: Single Ply / Thermal

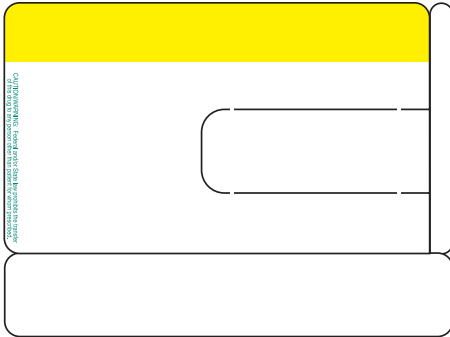

### Meditab-SuiteRX Pharmacy Software

Die # 500N

Size: 3 11/16" x 3 7/8"

Paper: Thermal

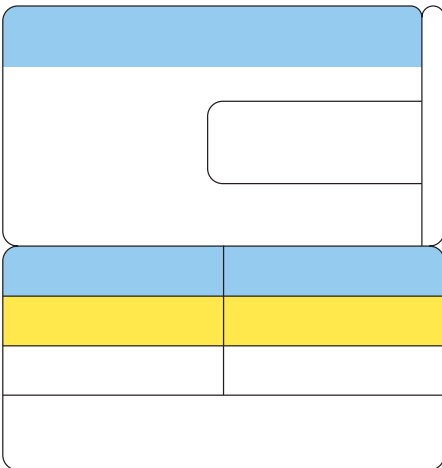

Die # 506

Size: 3 1/2" x 2 7/8"

Paper: Thermal

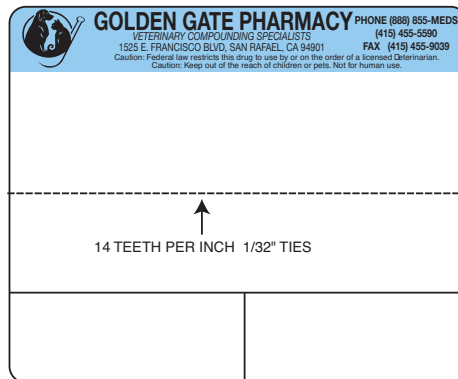

Die # 350T

Size: 3 11/16" x 2 3/4"

Paper: Single Ply / Thermal

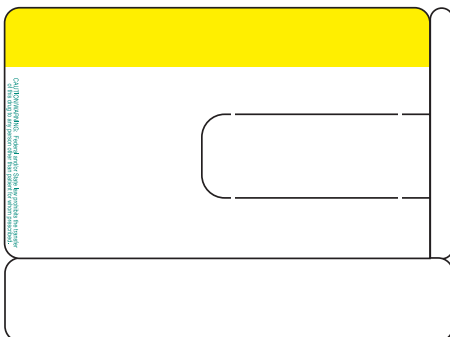

### Prodigy Software Labels

#### Die # 350T

Size: 3.688" x 2.75"

Paper: Single Ply / Thermal

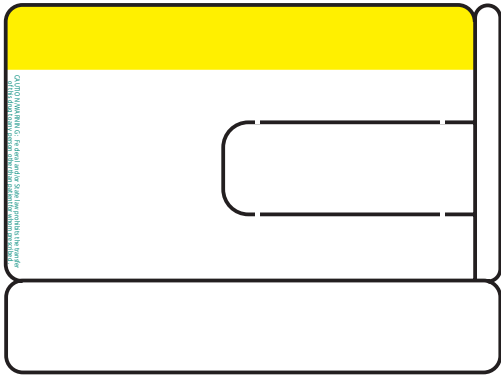

#### Die # 497

Size: 3 1/2" x 2 7/8"

Paper: Single Ply / Thermal

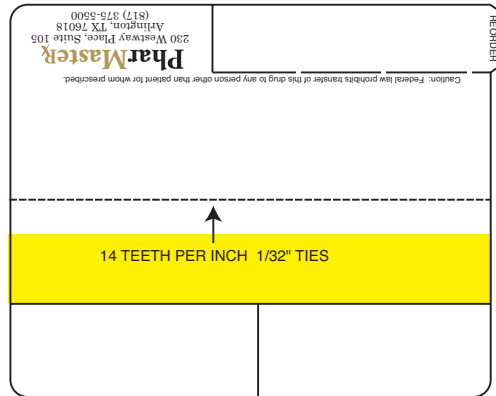

#### Die # 509

Size: 3.25" x 4.3125"

Paper: Single Ply / Thermal

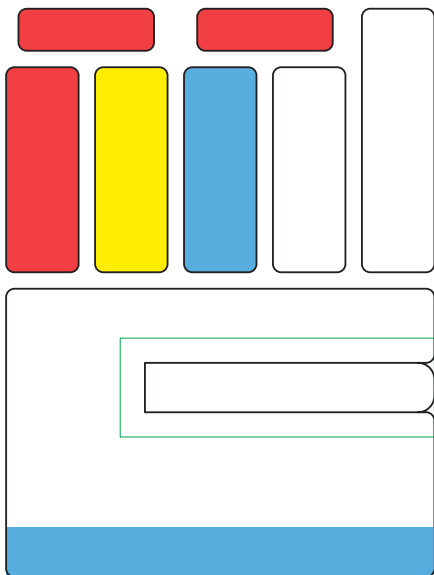

### Rescot Software Labels

#### Die # 443

Size: 3 5/8" x 2 7/16"

Paper: Thermal

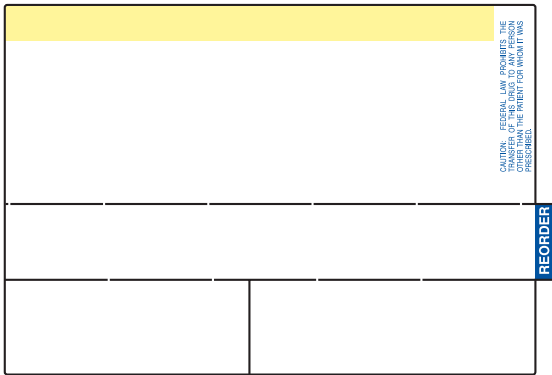

#### Die # 546

Size: 4" x 2 3/8"

Paper: Direct Thermal

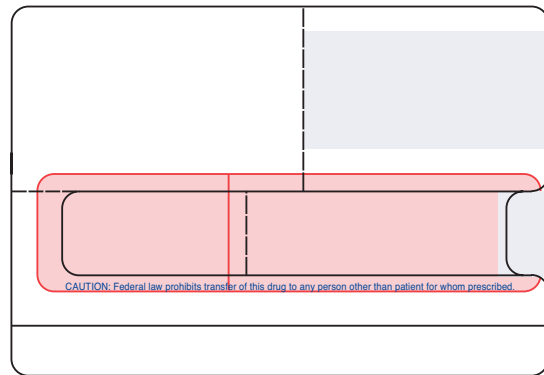

#### Die # 393

Size: 3 3/4" x 4 1/4"

Paper: Single Ply / Thermal

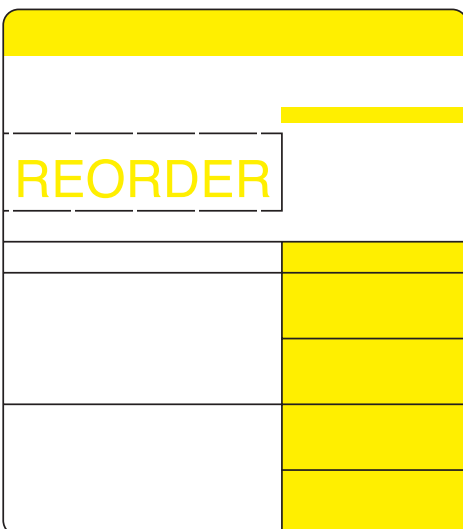

#### Die # 73

Size: 3 1/2" x 4 7/8"

Paper: Direct Thermal

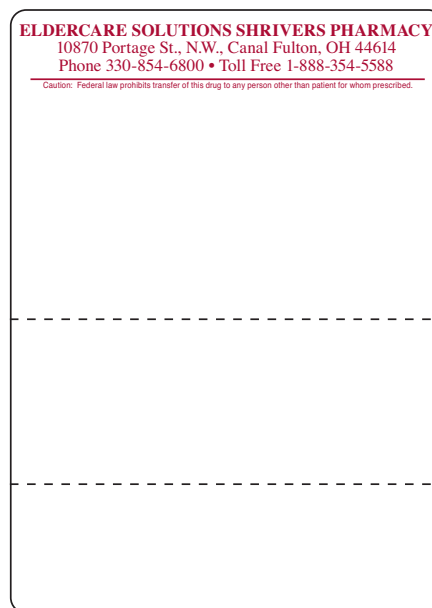

### RNA Software Labels

#### Die # 494

Size: 4" x 2 7/8"

Paper: Thermal

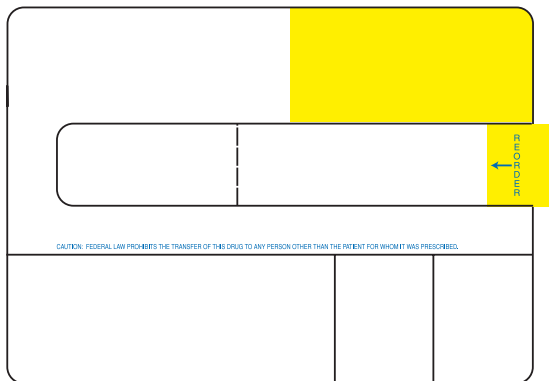

#### Die # 84N

Size: 4" x 2 1/2"

Paper: Single Ply / Thermal

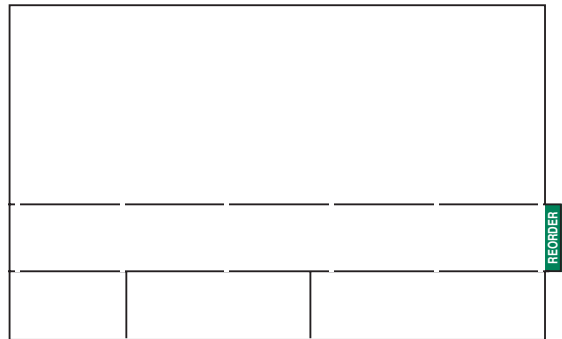

#### Die # 424T

Size: 3 11/16" x 3 5/8"

Paper: Single Ply / Thermal

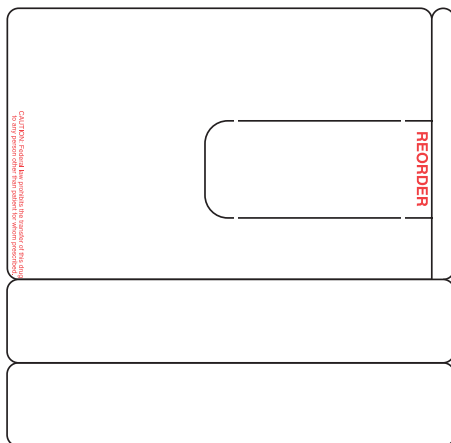

#### Die # 471

Size: 3 9/16" x 2 1/2"

Paper: Thermal

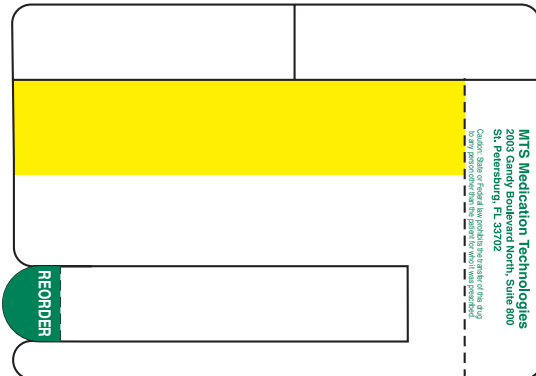

### RNA Software Labels

#### Die # 73

Size: 3 1/2" x 2 7/8"

Paper: Thermal

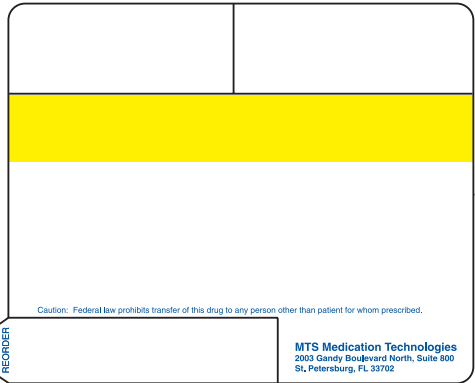

#### Die # 378X

Size: 3 1/8" x 2 3/8"

Paper: Single Ply / Twin Ply

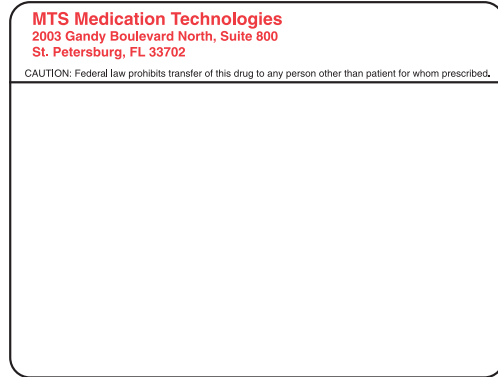

#### Die # 84C

Size: 4" x 2 1/2"

Paper: Single Ply / Thermal

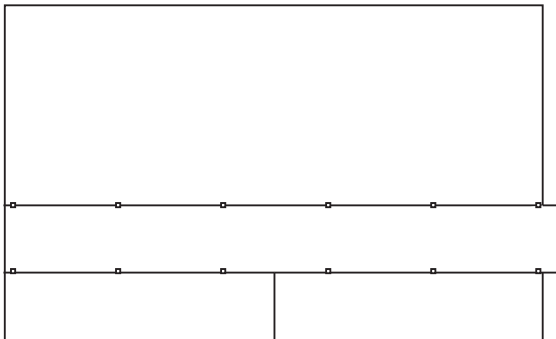

#### Die # 420

Size: 4 3/32" x 2 1/2"

Paper: Single Ply / Thermal





### RNA Software Labels

#### Die # 466

Size: 2 1/4" x 3 1/8"

Paper: Single Ply / Thermal



#### Die # 535

Size: 4" x 3 3/8"

Paper: Thermal

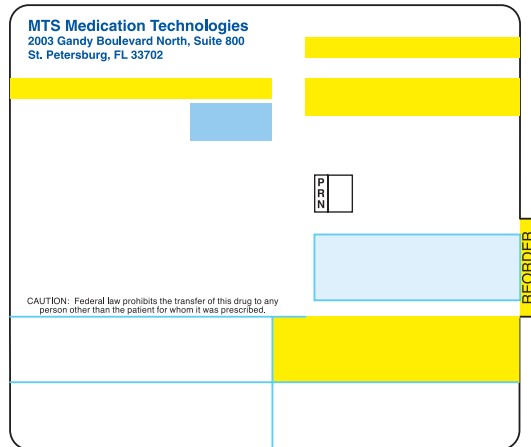

#### Die # 506

Size: 3 1/2" x 2 7/8"

Paper: Thermal

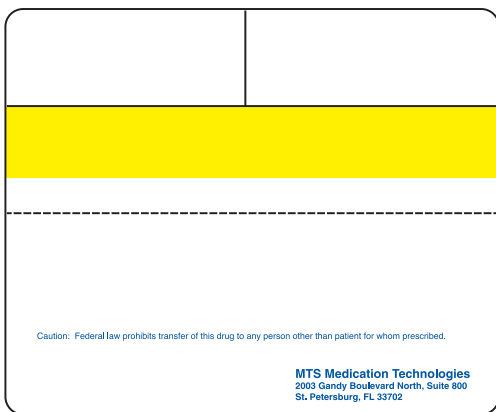

#### Die # 350T

Size: 3 11/16" x 2 3/4"

Paper: Single Ply / Thermal

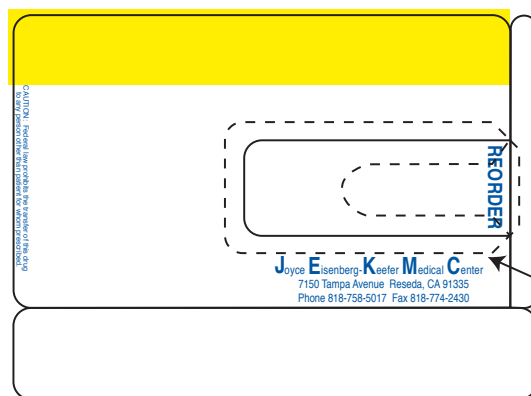

**RX30 Pharmacy Management Systems**

**Die # 471**

Size: 3 9/16" x 2 1/2"

Paper: Thermal

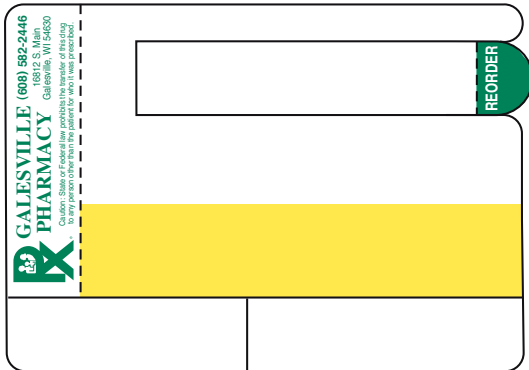

**Die # 555**

Size: 3 1/2" x 5 1/16"

Paper: Thermal

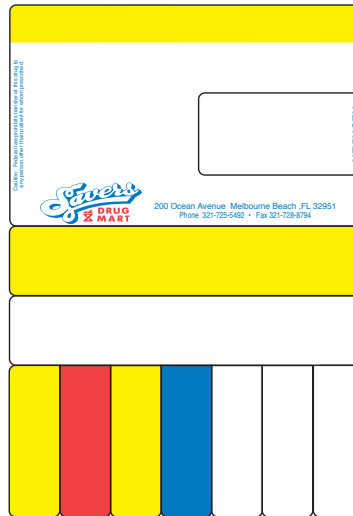

**Die # 500N**

Size: 3 11/16" x 3 7/8"

Paper: Thermal

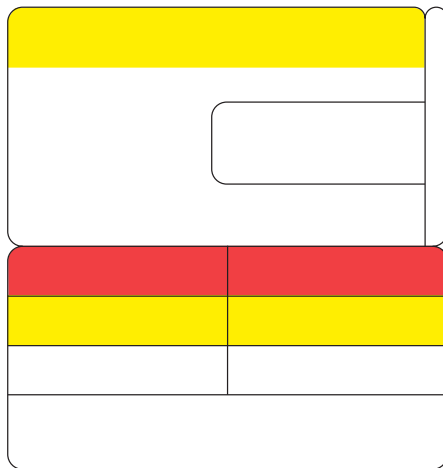

**Die # 350T**

Size: 3 11/16" x 2 3/4"

Paper: Single Ply / Thermal

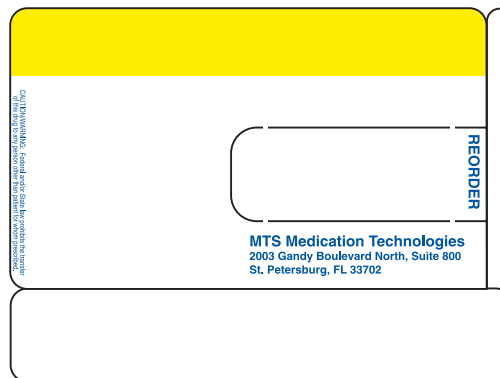



**Softwriters Framework Software Labels**

---

Die# L-TRX-012-L-027

Size: 3" X 4 1/8"

Paper: Thermal

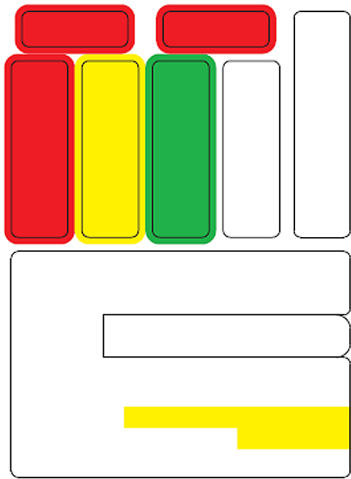

Die# L-TRX-16-555

Size: 3 1/2" X 5 1/16"

Paper: Thermal

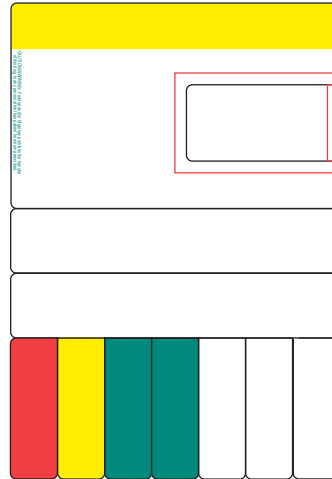

Die# L-TRX-025-566

Size: 4" X 2 3/4"

Paper: Thermal

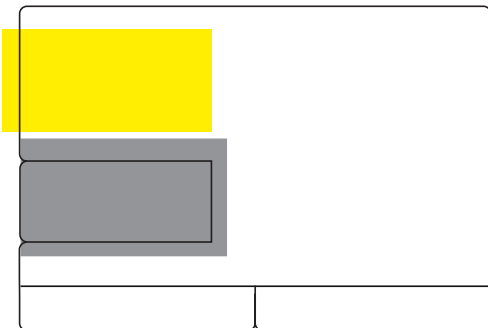

Die# L-TRX-027

Size: 3" X 2"

Paper: Thermal

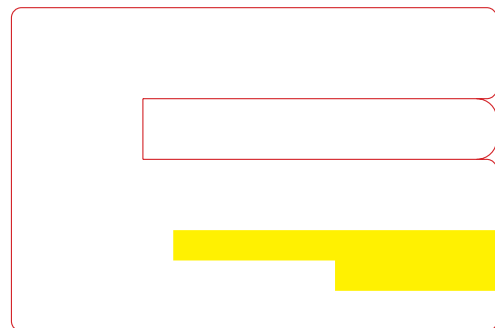

### Softwriters Framework Software Labels

---

Die# L-TRX-062

Size: 4 3/8" X 1 3/8"

Paper: Thermal

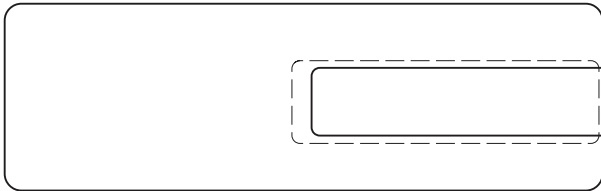

Die# L-TRX-070

Size: 4" X 2 1/4"

Paper: Thermal

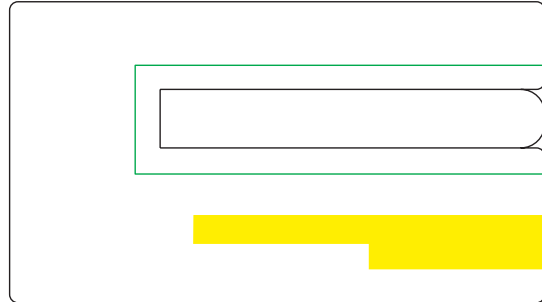

Die# L-TRX-071

Size: 3" X 4 1/8"

Paper: Thermal

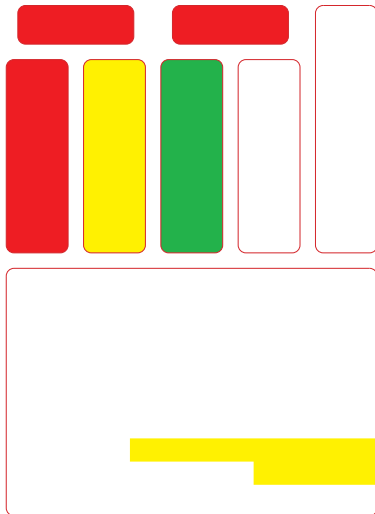

### QS1 Software Labels

---

#### Die # 350T

Size: 3 11/16" x 2 3/4"

Paper: Single Ply / Thermal

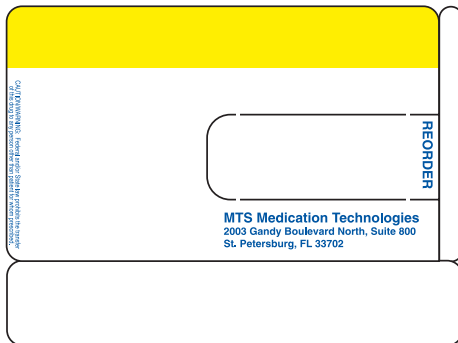

#### Die # 419

Size: 3 5/16" x 3 7/8"

Paper: Single Ply

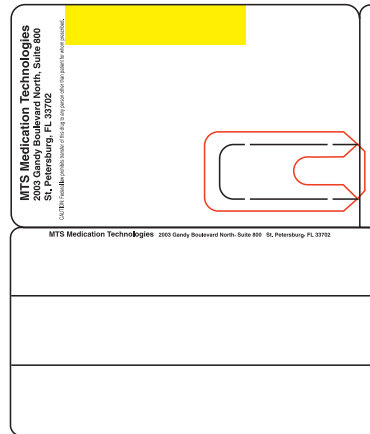

#### Die # 424T

Size: 3 11/16" x 3 5/8"

Paper: Single Ply / Thermal

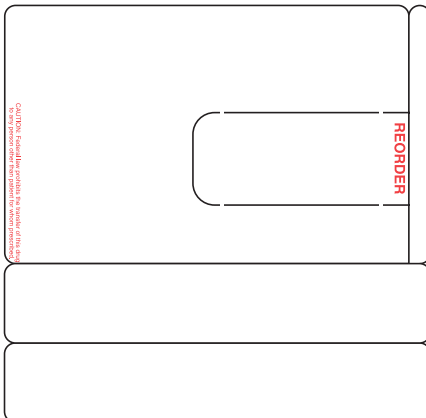

#### Die # 505

Size: 3 11/16" x 2 3/4"

Paper: Thermal Piggyback

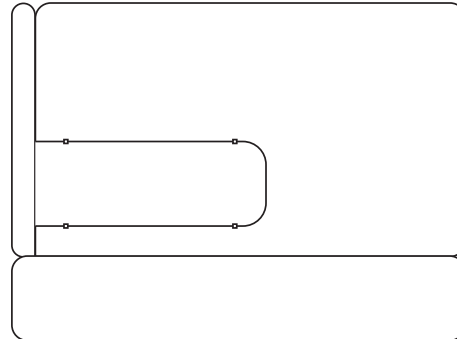

### QS1 Software Labels

#### Die # 443

Size: 3 5/8" x 2 7/16"

Paper: Single Ply / Thermal

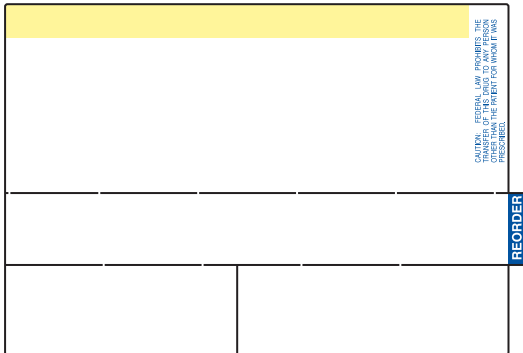

#### Die # 466

Size: 2 1/4" x 3 1/8"

Paper: Single Ply / Thermal

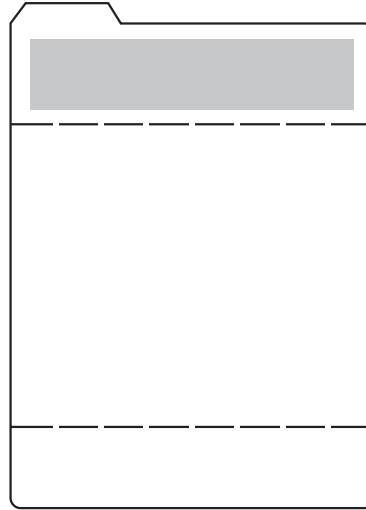

#### Die # 226

Size: 3 3/4" x 1 3/8"

Paper: Twin Ply

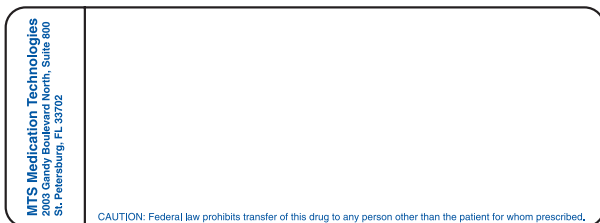

#### Die # 420

Size: 4 3/32" x 2 1/2"

Paper: Single Ply / Thermal

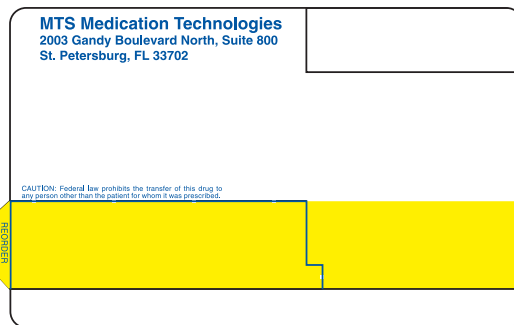



### QS1 Software Labels

#### Die # 136

Size: 3 1/4" x 1 15/16"

Paper: Single Ply / Twin Ply

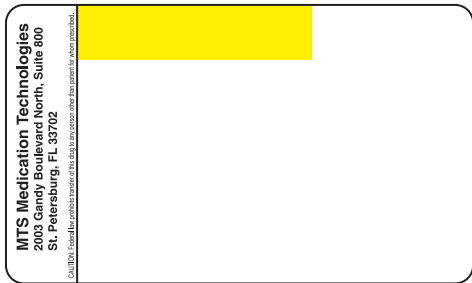

#### Die # 453

Size: 4" x 1 27/32"

Paper: Single Ply / Thermal

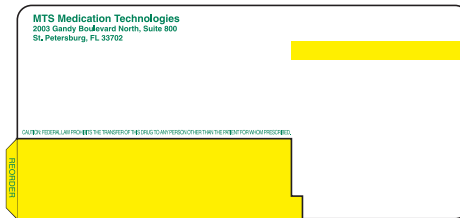

#### Die # 459

Size: 3 3/8" x 2 5/8"

Paper: Single Ply / Thermal

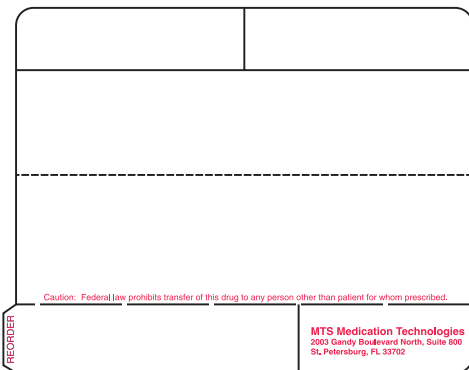

#### Die # 506

Size: 3 1/2" x 2 7/8"

Paper: Single Ply / Thermal

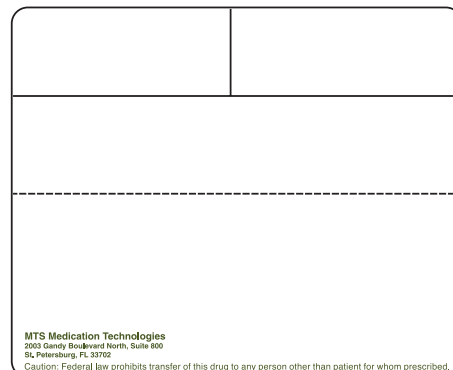

### QS1 Software Labels

#### Die # 393

Size: 3 3/4" x 4 1/4"

Paper: Single Ply / Thermal

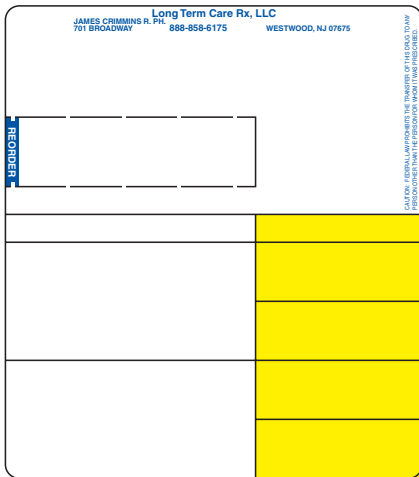

#### Die # 541

Size: 3 7/8" x 3 7/16"

Paper: Single Ply / Thermal

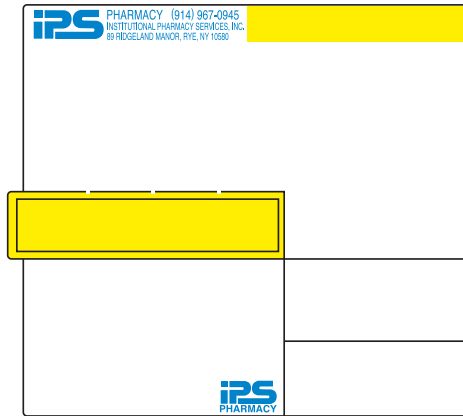

#### Die # 500N

Size: 3 11/16" x 3 7/8"

Paper: Thermal

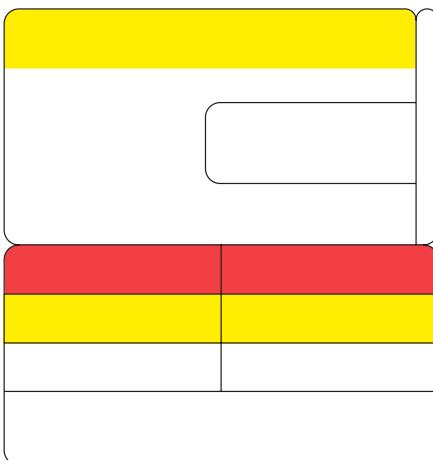

#### Die # 502SE

Size: 7 7/8" x 4"

Paper: Thermal

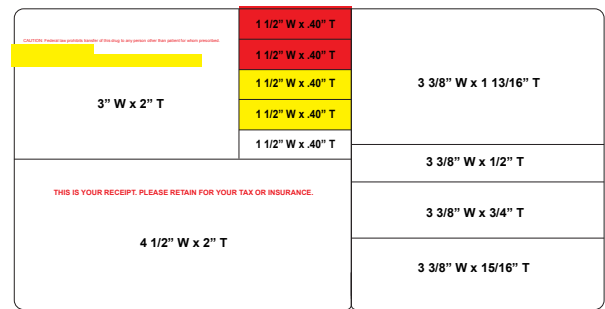

### QS1 Software Labels

#### Die # 592

Size: 3 3/4" x 3 3/16"

Paper: Thermal

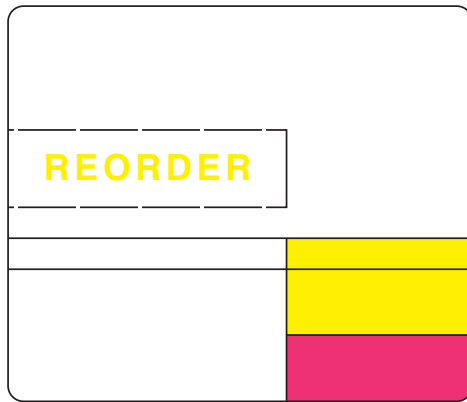

#### Die # 581

Size: 4" x 6 1/4"

Paper: Thermal

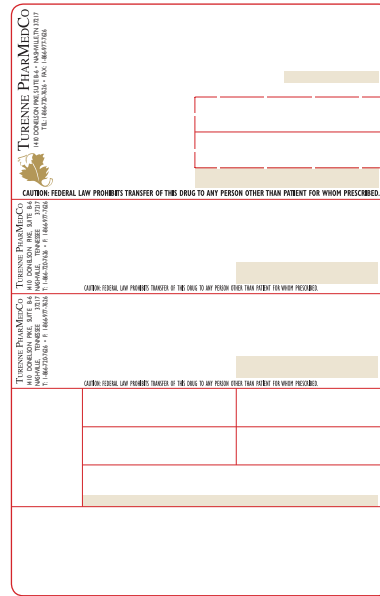

#### Die # 569

Size: 3 1/16" x 4 1/8"

Paper: Thermal

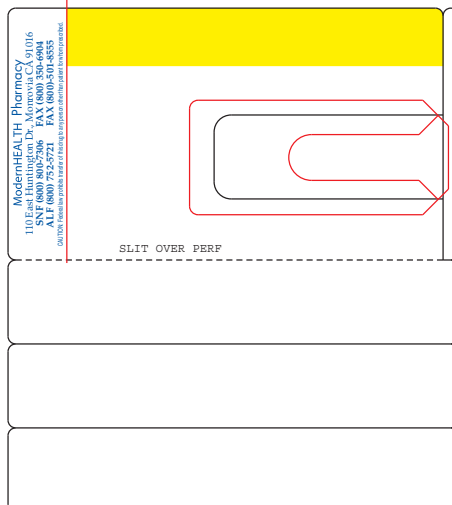

#### Die # 486

Size: 2 1/2" x 2 5/8"

Paper: Thermal

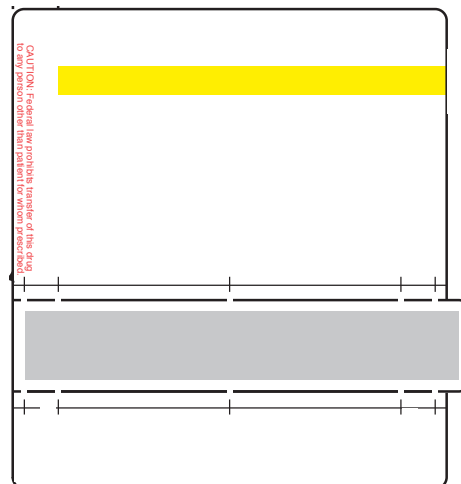

### QS1 Software Labels

---

#### Die # 629

Size: 3 11/16" x 3 7/8"

Paper: Thermal

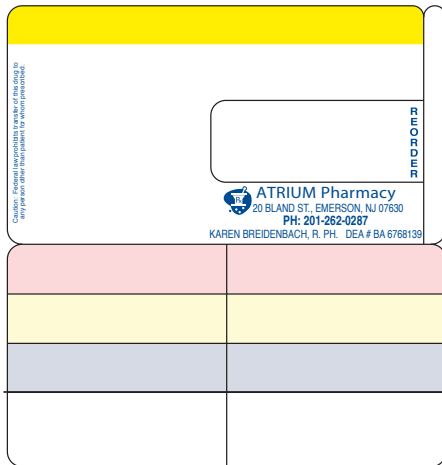

#### Die # 59

Size: 2 3/4" x 1 15/16"

Paper: Single Ply/Twin Ply

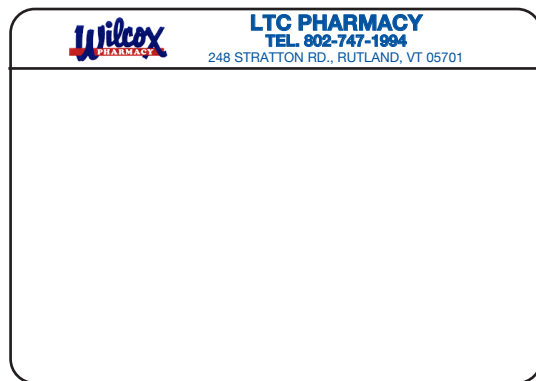

### Ribbons

---



Omnicell quality does not stop at labels. We have some of the finest quality thermal transfer ribbons at some of the best prices available anywhere.

Our Omnicell Ribbons work with the following printers:

- Datamax
- Cognitive
- Eltron
- Intermec
- Zebra
- Sato
- Printronix
- RJS
- Tharo
- And Many Other Printers

Call us for a quote: (800) 671-8439

# Labels & Printing Supplies

## Foil

**Foil:** Omnicell foil lidding stock is available in a number of styles. Used for the printing of drug information for both Unit Dose and Select Seal Punch Card products.

### Dot Matrix Foil

Item #680-10

- Universal, 1,000/Roll

Used in conjunction with MTS unit dose blisters and the Select Seal Reclaimable Punch Card. Printing is done via Dot Matrix such as the Okidata 320 turbo.

**Product page 47**

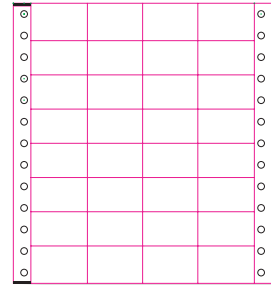

### Thermal Transfer Foil

Item #680-11

- Universal, 1,000/Roll

Used in conjunction with MTS unit dose blisters. Printing is done via a high-speed thermal transfer printer e.g. Cab, Apollo, Datamax, Zebra or similar device. Package can be used in a unit dose box or inserted into a Select Seal Reclaimable Punch Card.

*Recommended Accessories:*

*TTR Ribbon #TTR-007*

**Product page 47**

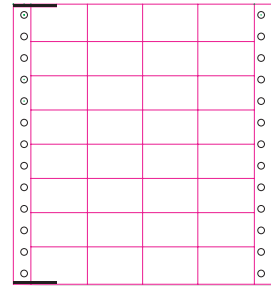

### Thermal Transfer

Item #680-19

- Select Seal, 1,000/Roll

Used in conjunction with the MTS Select Seal Reclaimable Punch Card. Printing is done via a high-speed thermal printer such as an Apollo, Cab, Datamax, Zebra, etc. Foil width is sized for the Select Seal Card. Used for a one-step sealing process of foil, card and blister.

*Recommended Accessories:*

*TTR Ribbon #TTR-007*

**Product page 47**

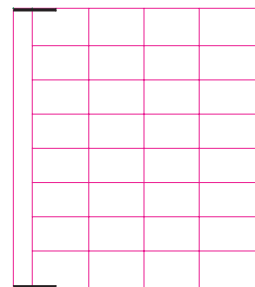

Thermal Transfer Item #680-25  
- Select Seal, 1,000/Roll

Specifically rolled and designed for Oasis Software.

**Product page 47**

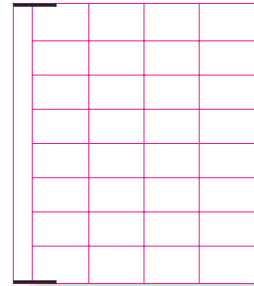

Thermal Transfer Foil for OnDemand 400 Item #680-38  
7x4 Standard, 1,000/Roll

Used in conjunction with standard size perforated packaging for OD400 item #300-90.

**Product page starting on page 20**

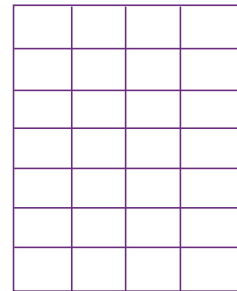

Large Thermal Transfer Foil for OnDemand 400 Item #680-39  
7x4 Large, 1,000/Roll

Used in conjunction with large size perforated packaging for OnDemand item #301-90.

**Product page starting on page 20**

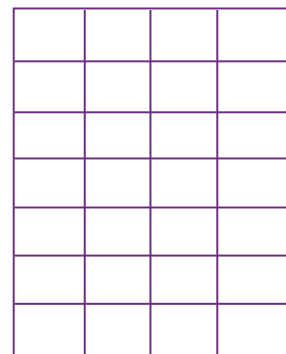

# Looking for a Competitive Advantage

## SureMed by Omnicell Custom Print Options

- Logo prominently displayed attracts new customers
- Small minimum order - only 1500 cards
- Fast turnaround time - just 14 business days
- Exclusive online portal for live customization



## Now You Can Order Online!

### SureMed by Omnicell Digital StoreFront

The most convenient, easy-to-use, customized buying experience for medication packaging



Visit [shopomnicell.com](http://shopomnicell.com) to Register Today!

Omniceil, Inc.  
Mountain View, CA • St. Petersburg, FL • Raleigh, NC  
800-671-0589  
[www.omnicell.com](http://www.omnicell.com)

Omniceil, the Omnicell design mark, and SureMed are registered trademarks of Omnicell, Inc. in the United States and internationally. All other trademarks and names are the property of their respective owners. ©2020 All rights reserved. PN955 Rev D 03/20

